

# Analogue Media Technologies Inc. Printing Templates – Beta version

This document contains dozens of templates and folding diagrams for many of the products we print. You may use these templates in programs like Corel Draw, Adobe Illustrator, Quark Express, Freehand, etc...

If reading this document in Adobe Acrobat, notice that the page size is 17” high by 27” wide. It is not really designed for printing on a desktop printer, although you could print selected pages by tiling the output.

Using these templates

Method 1 -Copy and paste

- Zoom Acrobat reader to “Actual size” or 100%
- Press the “Graphic select” icon (hint: press and hold the “Text select” icon)
- “Select all” or Ctrl-A
- Copy
- Switch to your layout program, and Paste.
- You should then have an accurately sized color bitmap to work on.

Method 2 - Open this PDF document in Corel or Illustrator

- Find the template you want and copy it to your working document
- Note that this is a big document, so make sure you have sufficient computer power to open it.

Method 3 - Print to an EPS file

- If you have a postscript print driver, you should be able to print your selected page to a file, and then open this in Corel Draw or Illustrator.

Please note that we are in no way responsible for any errors you may make in using these templates. We recommend sending your finished file to us for film output, or having us do the layout for you.

You may notice some products contained herein are missing templates... These will be included as time permits and if demanded. If you do not see a product you are searching for, enquire to see if it is available.

We can also make a custom die for your project if needed. Please submit a mock-up of your idea. A die will generally cost \$500 US or more, depending on its complexity.

For assistance with these templates email [george@amtechdisc.com](mailto:george@amtechdisc.com) or call 1-800-777-1927.

Please note that these templates are all copyrighted and use of these templates and diagrams is only permitted for customers of Amtech. All use by other printing companies, die-making companies, media duplicators and replicators is strictly forbidden.

## Legend:

 TRIM

 FOLD

 PERFORATION

 MAXIMUM IMAGE  
(BLEED AREA)

## CD JEWEL BOX TRAY CARD INSERT

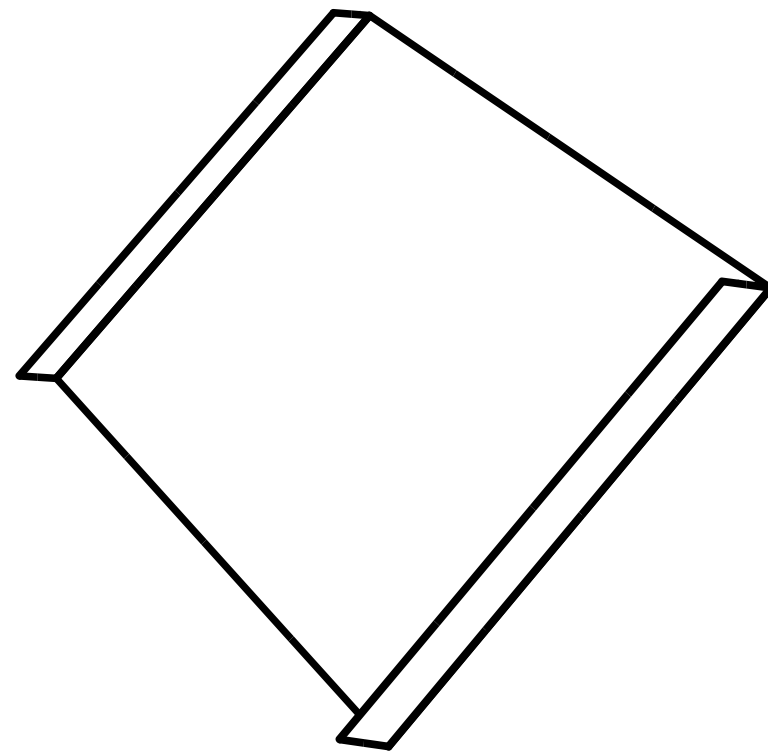

## CD JEWEL BOX FOLDER INSERTS

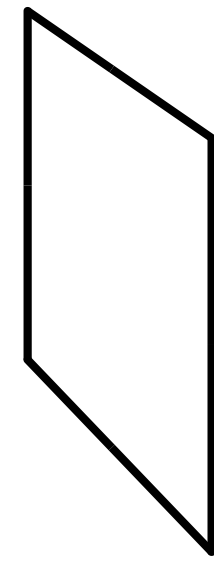

1 PANEL  
2 PAGE

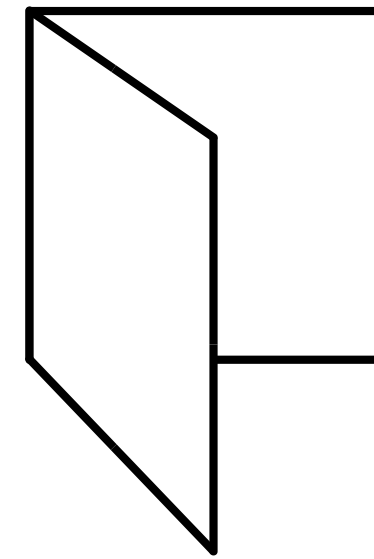

2 PANEL  
4 PAGE

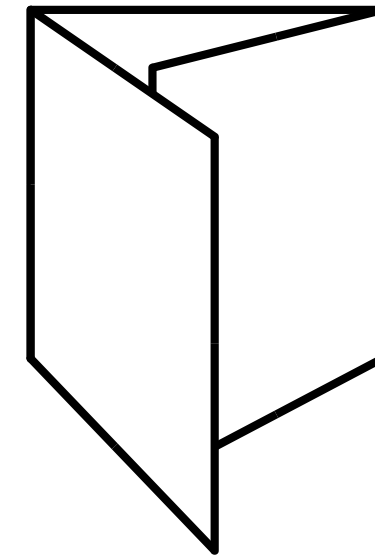

3 PANEL  
6 PAGE

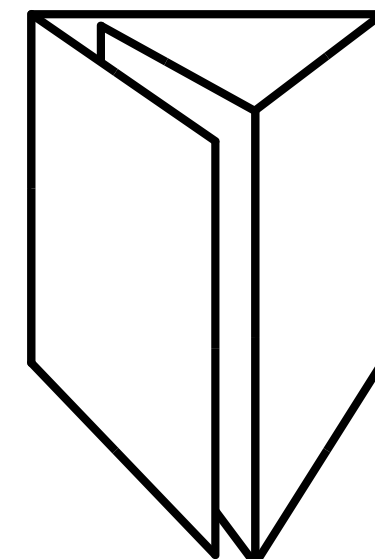

4 PANEL  
8 PAGE  
WRAP-AROUND

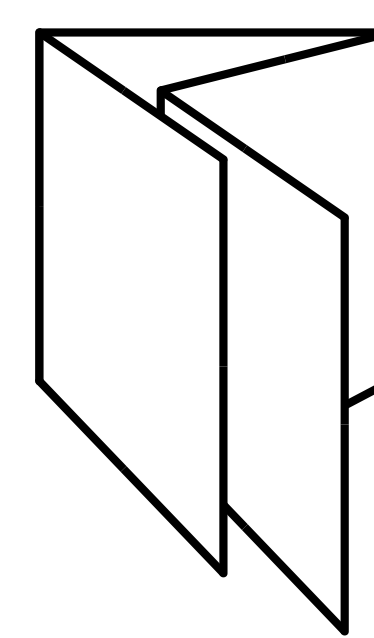

4 PANEL  
8 PAGE  
FOLD-TWICE

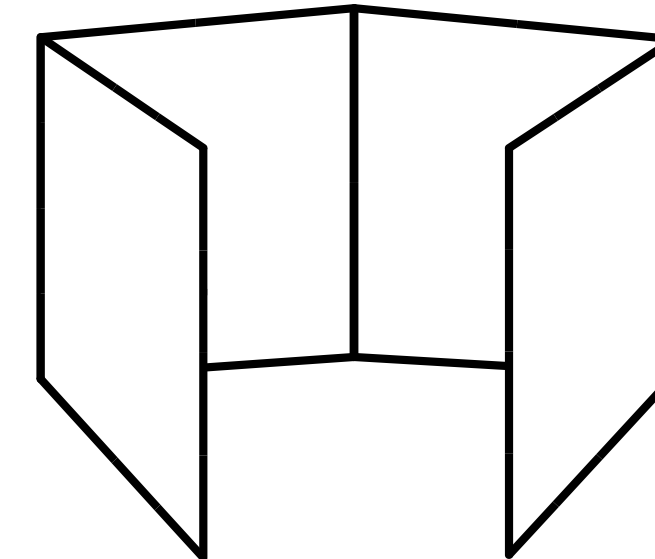

4 PANEL  
8 PAGE  
GATE-FOLD

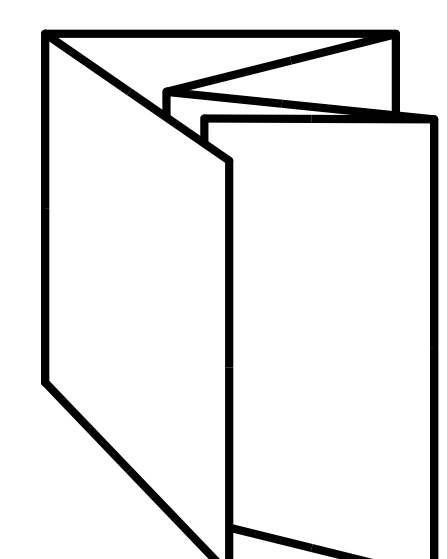

5 PANEL  
10 PAGE

## CD JEWEL BOX POSTER FOLDER INSERTS

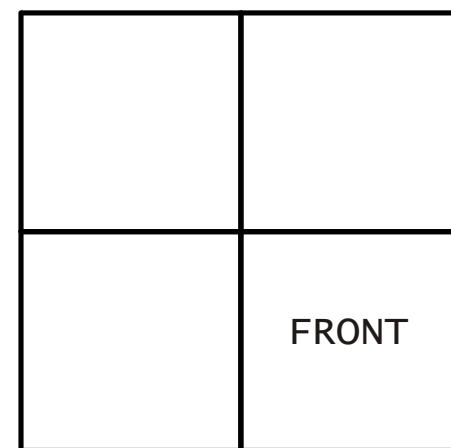

4 PANEL  
8 PAGE

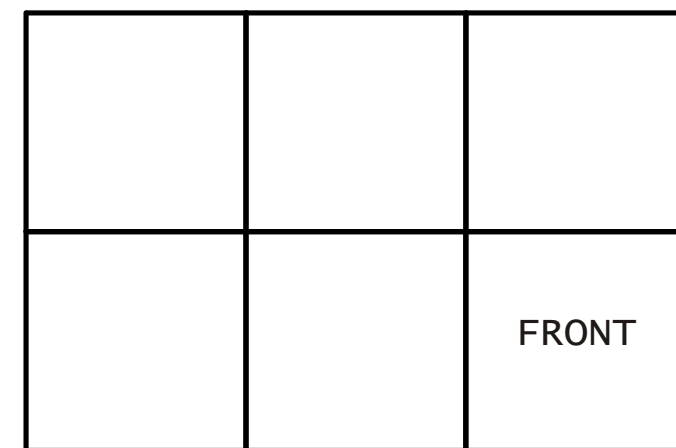

6 PANEL  
12 PAGE

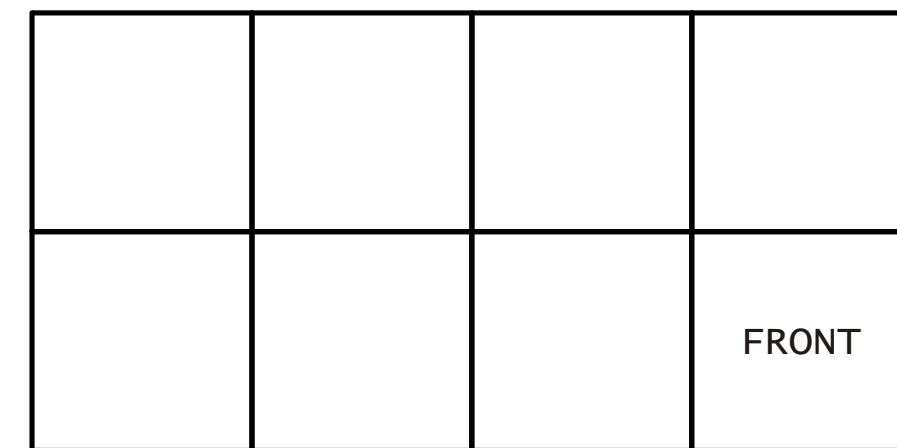

8 PANEL  
16 PAGE

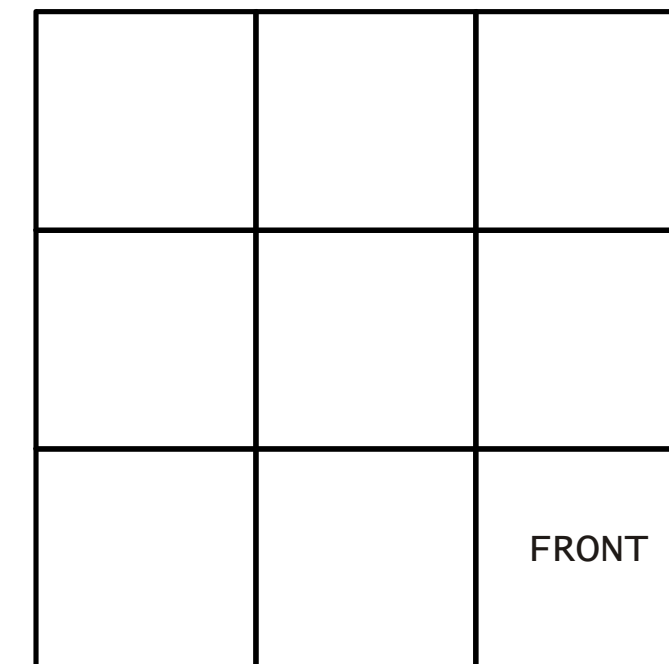

9 PANEL  
18 PAGE

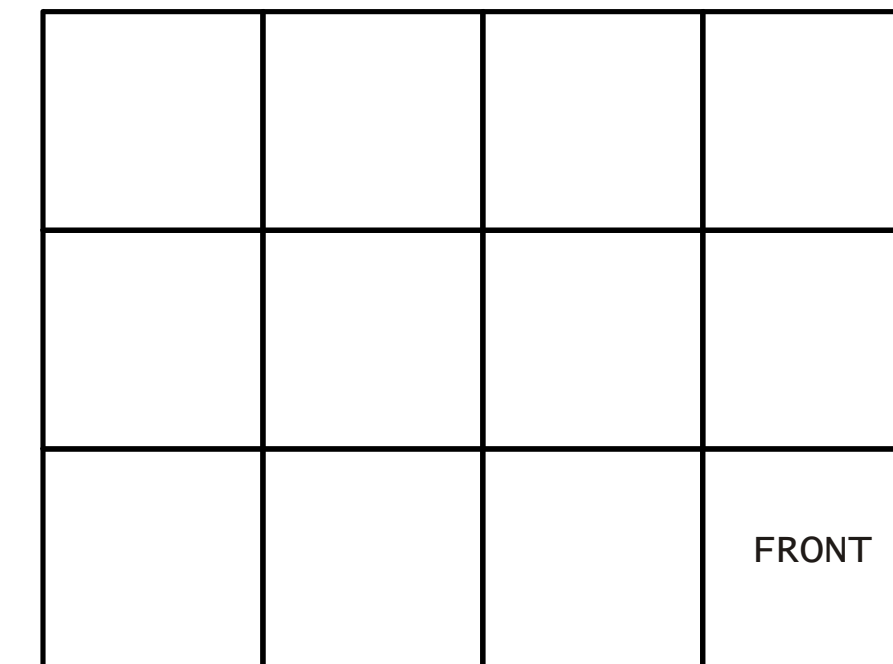

12 PANEL  
24 PAGE

## CD JEWEL BOX BOOKLET INSERTS

Use Design 21002, 2 panel folder, as the template for booklets. All pages must be supplied in printer spreads, not reader spreads (ie. Put together pages 1 & 16, 2 & 15, 3 & 14, etc...).

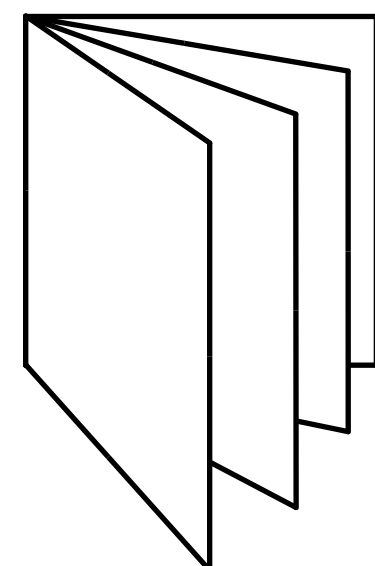

8 PAGE

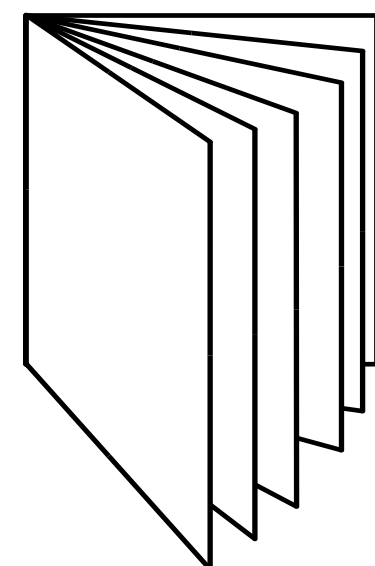

12 PAGE

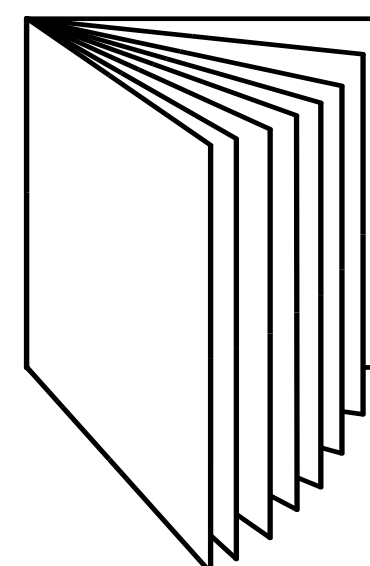

16 PAGE

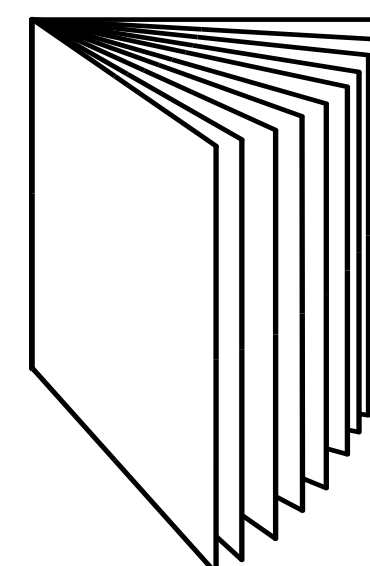

20 PAGE

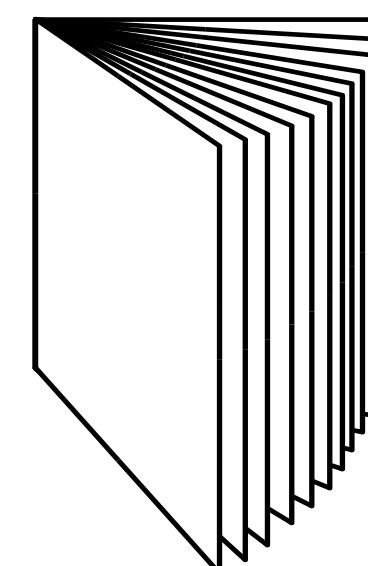

24 PAGE

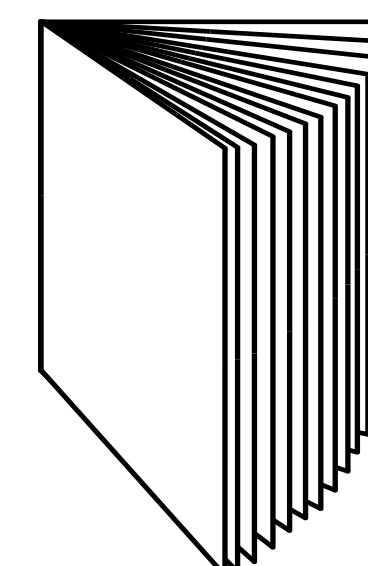

28 PAGE

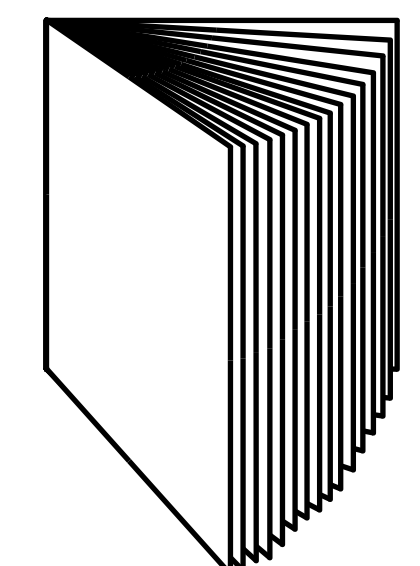

32 PAGE

## CD SLEEVES AND MAILERS - 1000 SERIES

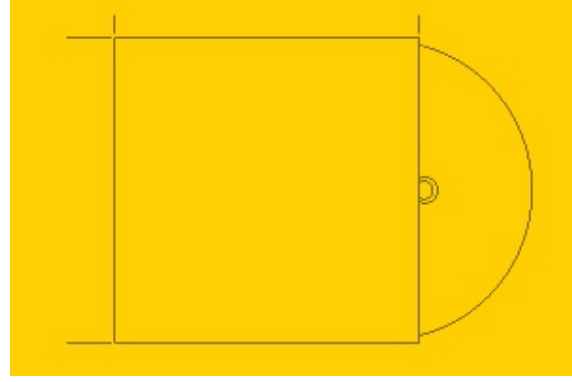

DESIGN 1000  
CD Mini Jacket

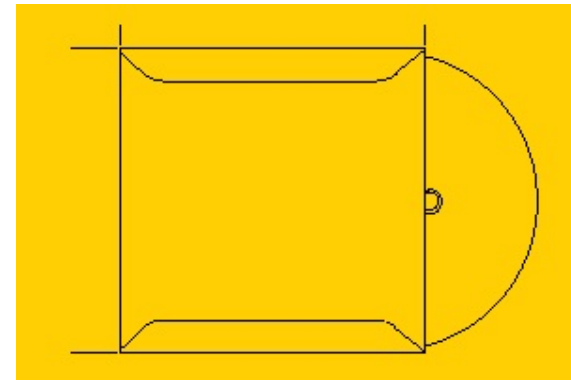

DESIGN 1001  
CD Mini Jacket  
Outside seam

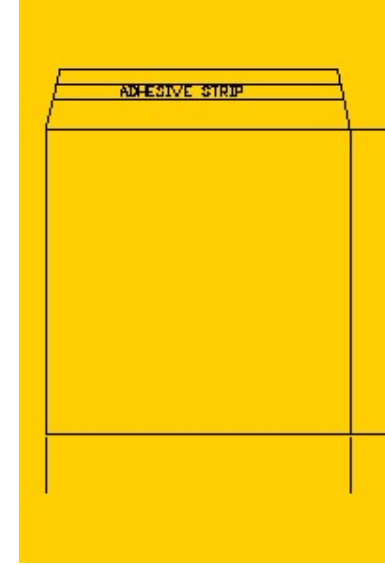

DESIGN 1002  
CD Mailer

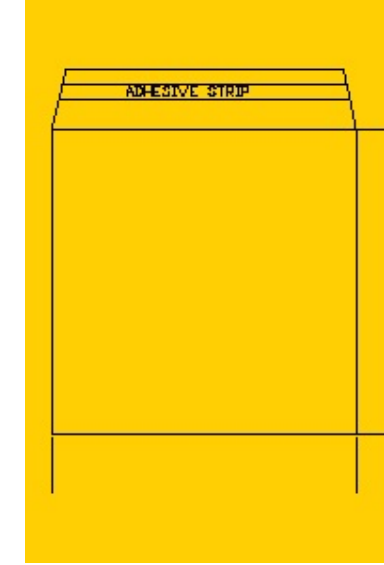

DESIGN 1003  
CD Mailer

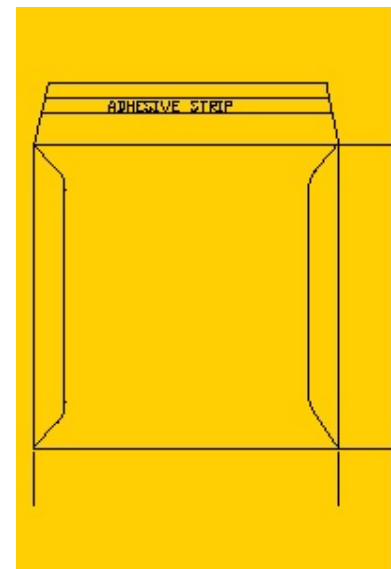

DESIGN 1004  
CD Mailer

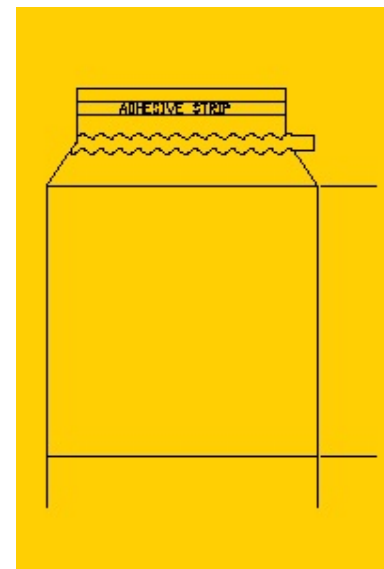

DESIGN 1005  
CD Mailer with zipper

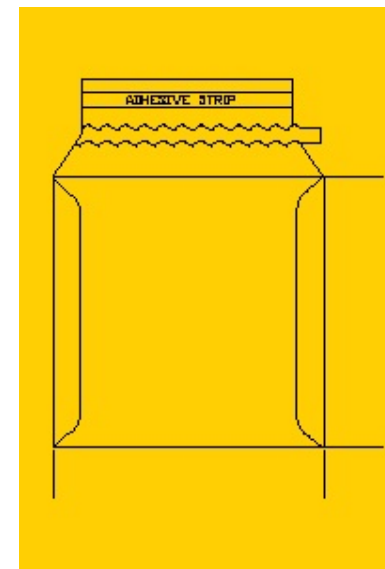

DESIGN 1006  
CD Mailer with zipper

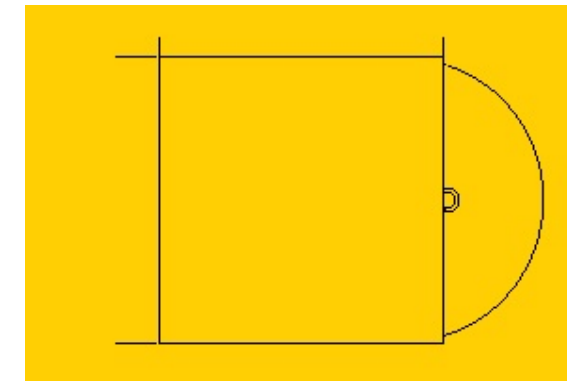

DESIGN 1007  
CD Mini Jacket

## CD SLEEVES AND MAILERS - 2000 SERIES

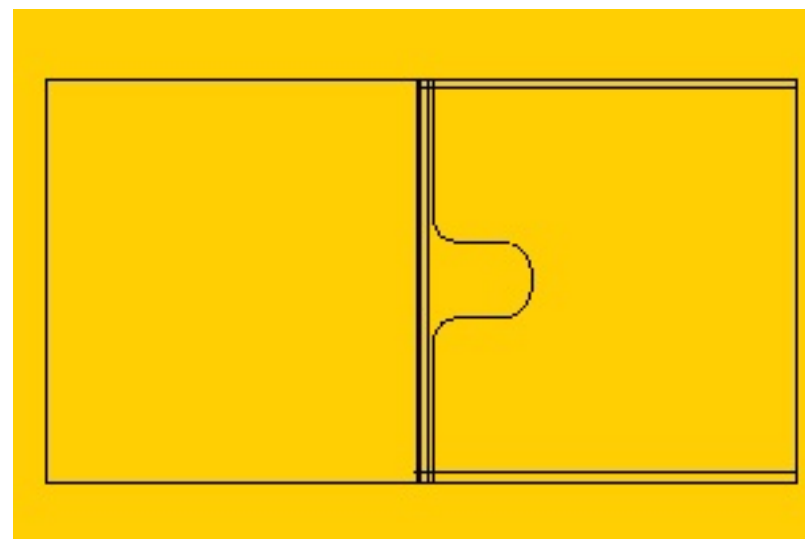

DESIGN 2000

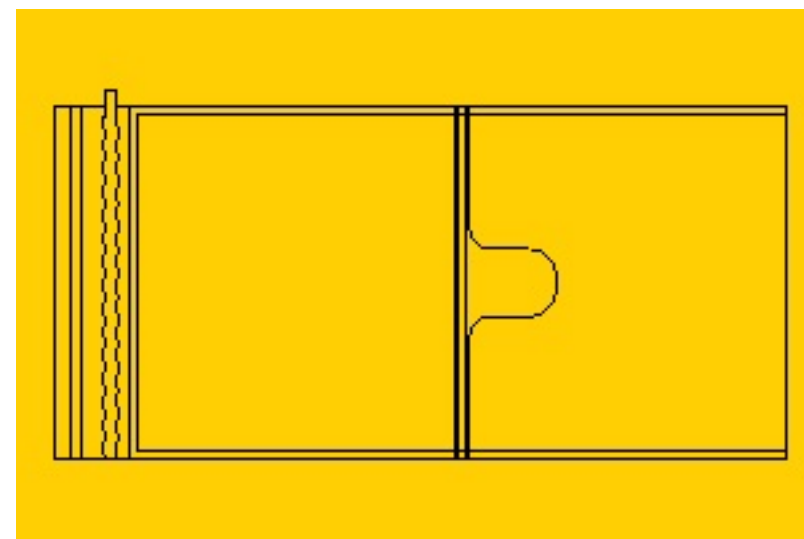

DESIGN 2001

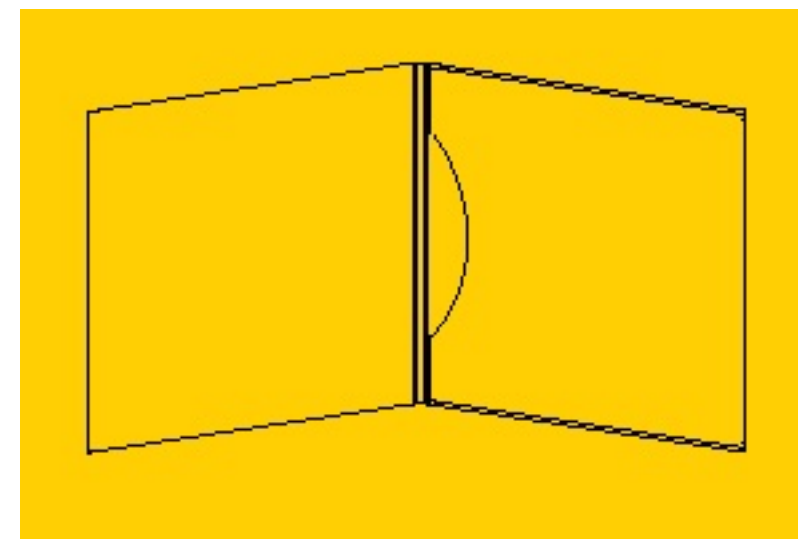

DESIGN 2002

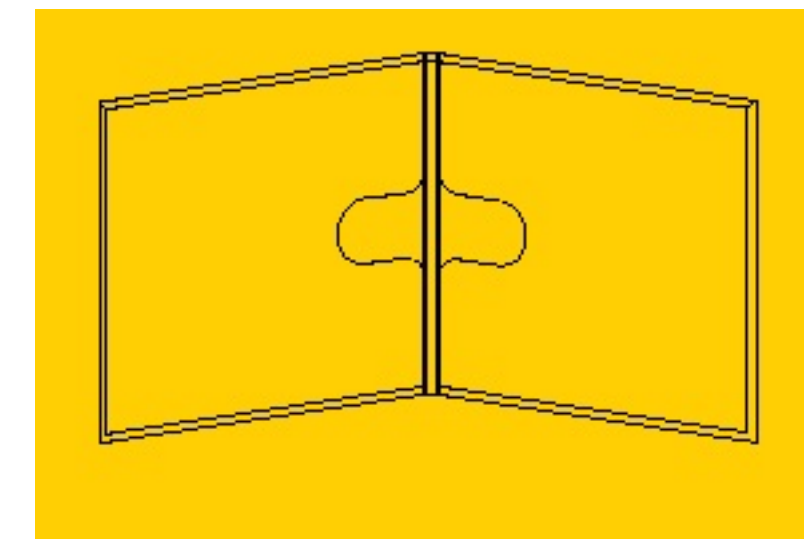

DESIGN 2003

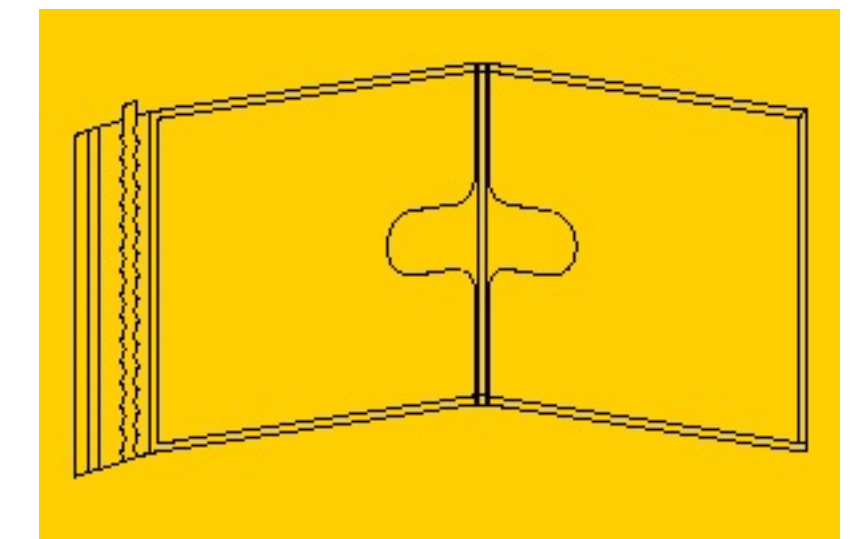

DESIGN 2004

# CD SLEEVES AND MAILERS - 3000 SERIES

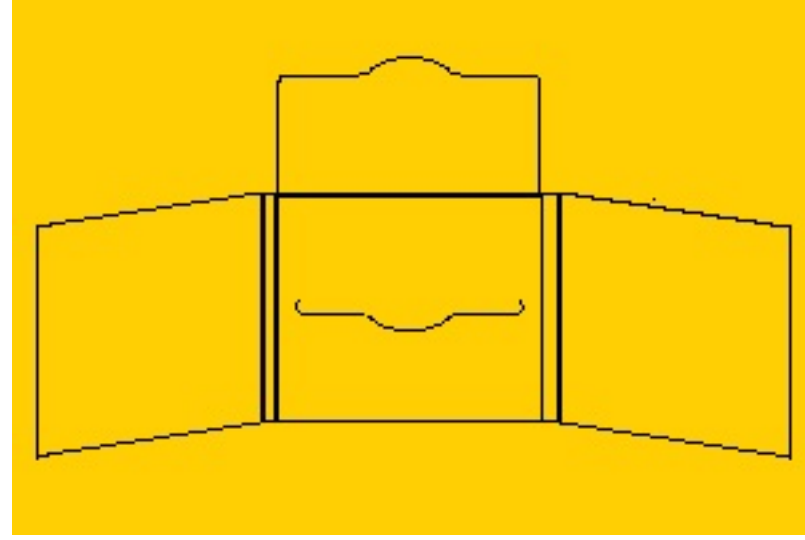

DESIGN 3000

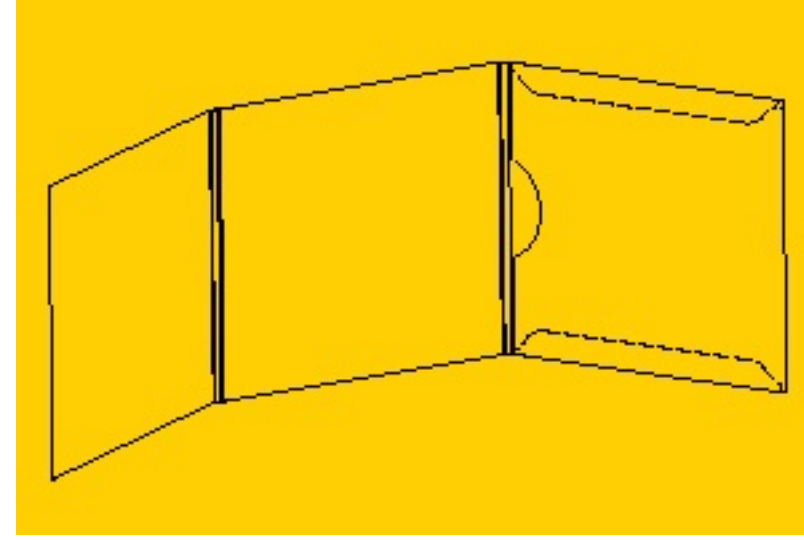

DESIGN 3001

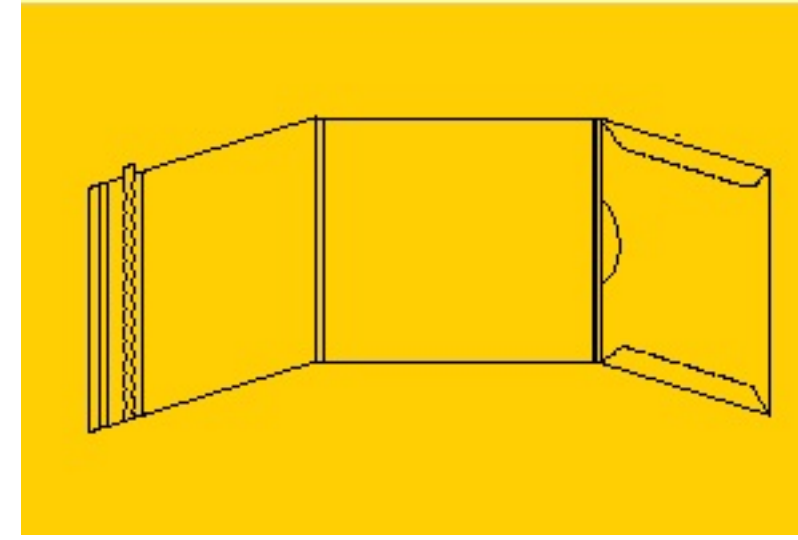

DESIGN 3002

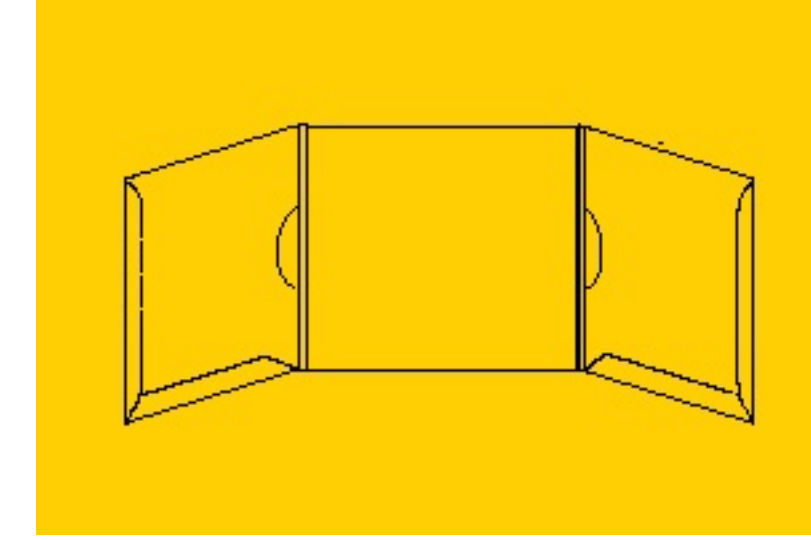

DESIGN 3003

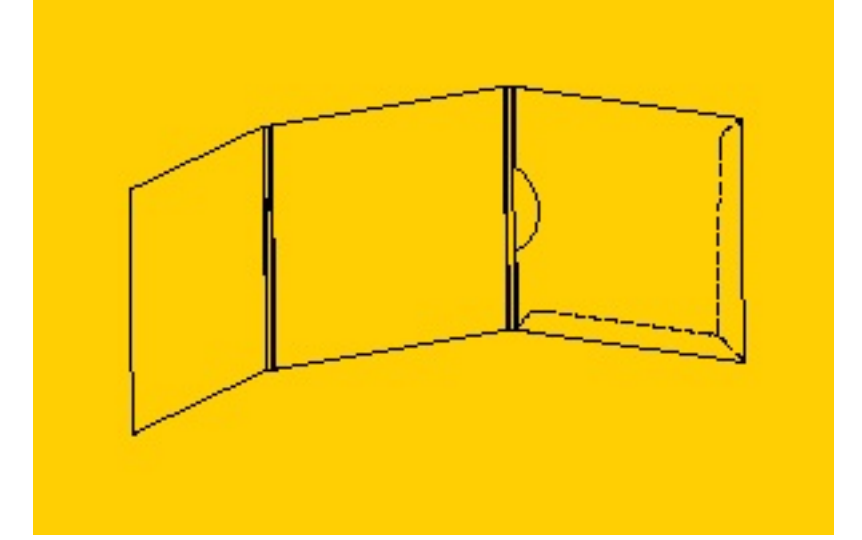

DESIGN 3004

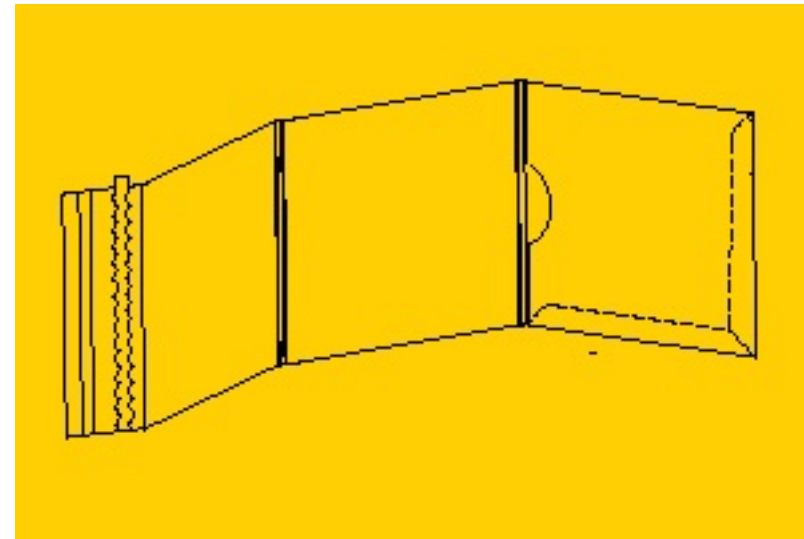

DESIGN 3005

# CD SLEEVES AND MAILERS - 4000 SERIES

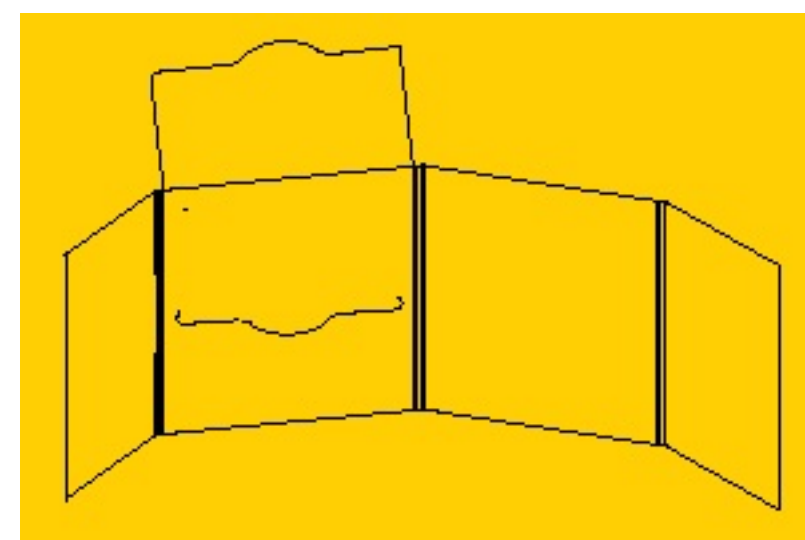

DESIGN 4000

# VIDEO BOX

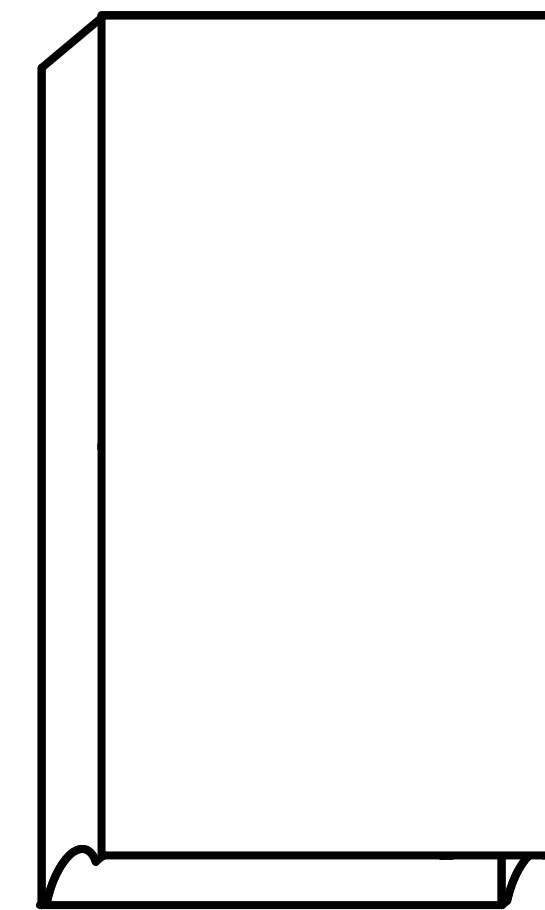



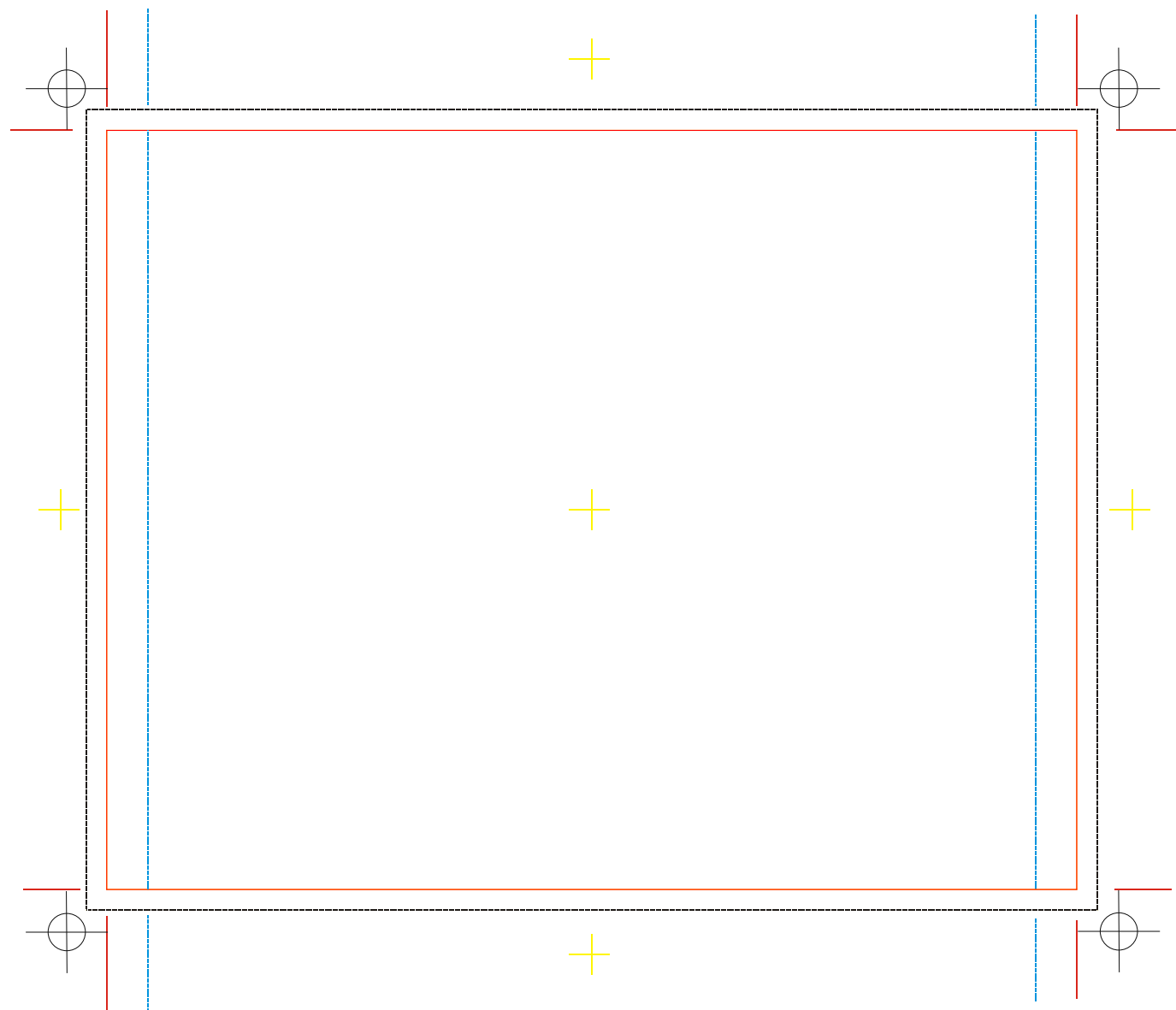

DESIGN 18001



PRINTED SIDE

Legend:

-  TRIM
-  FOLD
-  PERFORATION
-  MAXIMUM IMAGE (BLEED AREA)

REF. TRAY CARD  
 DESIGN # 21000  
 O.B. 4.625" X 5.9063"

The measurements of the tray card are extremely critical. Small deviations from the proper size may make the card unuseable on the automated machines, resulting in manual packaging fees. The spines must be perforated, not scored.

Normally the tray card should always contain the words "Made in Canada" for compliance with USA and international trade laws.

Please also create a selection number to use on all components for easy identification. For example: put something like MYCD01 on each spine, somewhere on the front insert, on the CD label, and on your master tape or CD.

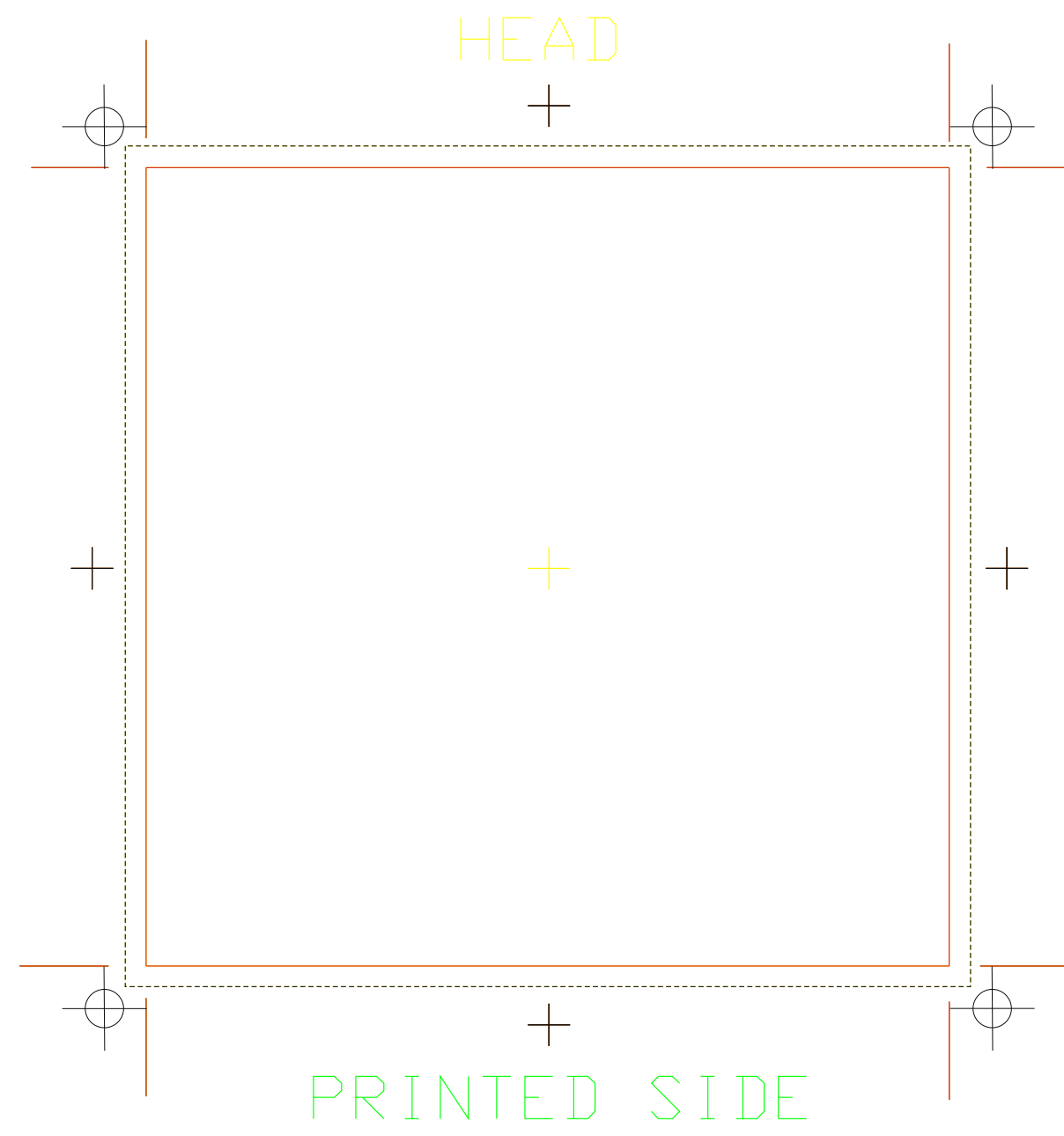

REF. 2 PAGE CARD  
DESIGN # 21001

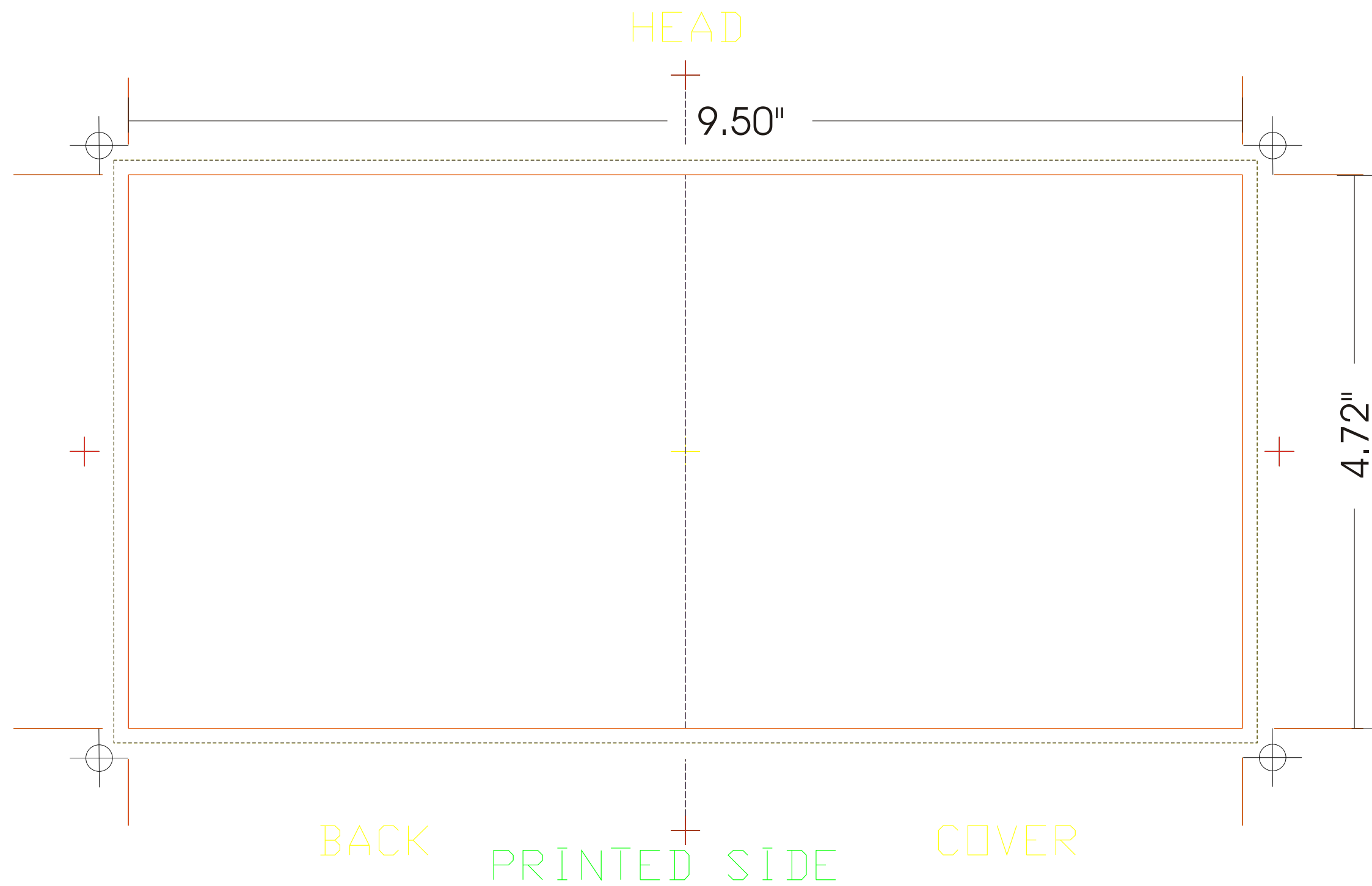

REF. 4 PAGE FOLDER  
DESIGN # 21002



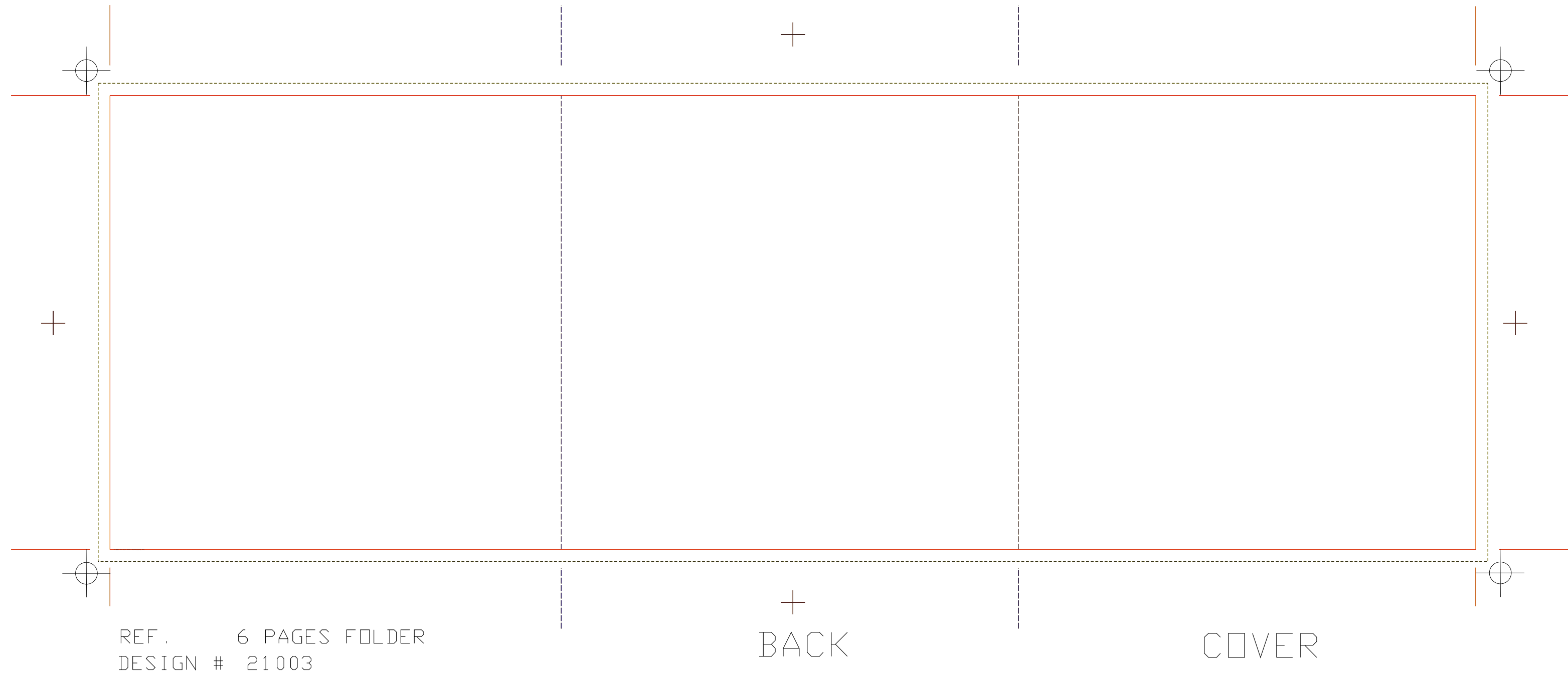



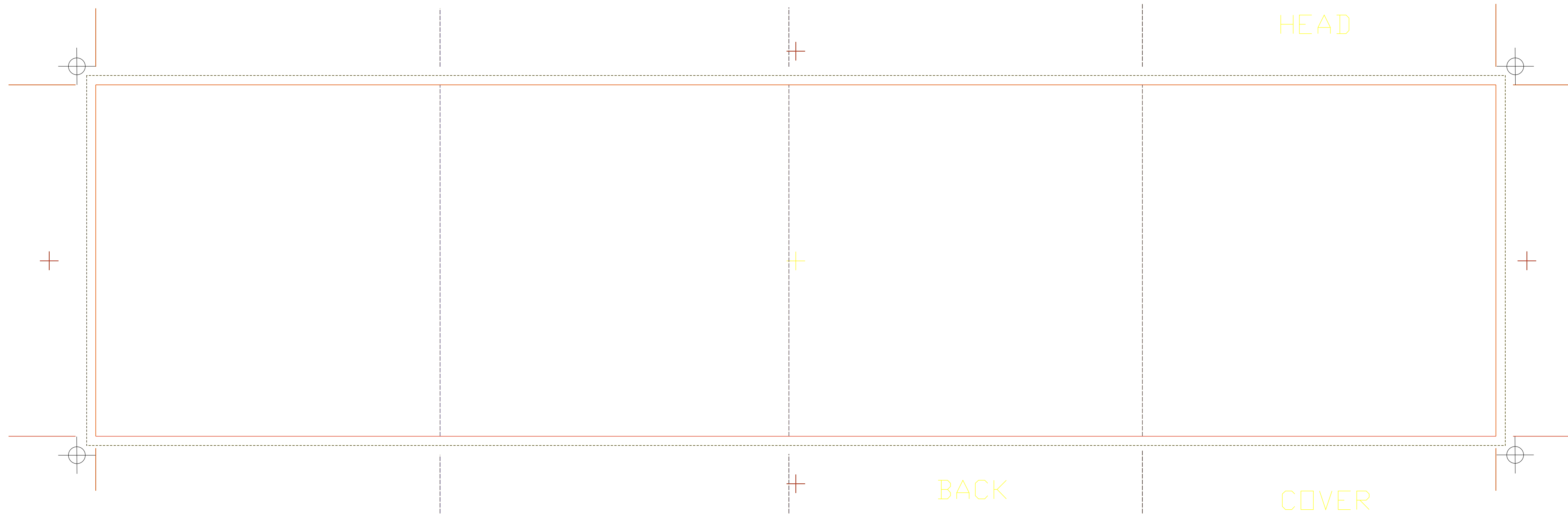

REF. 8 PAGE FOLDER " WRAP-AROUND"  
DESIGN # 21004

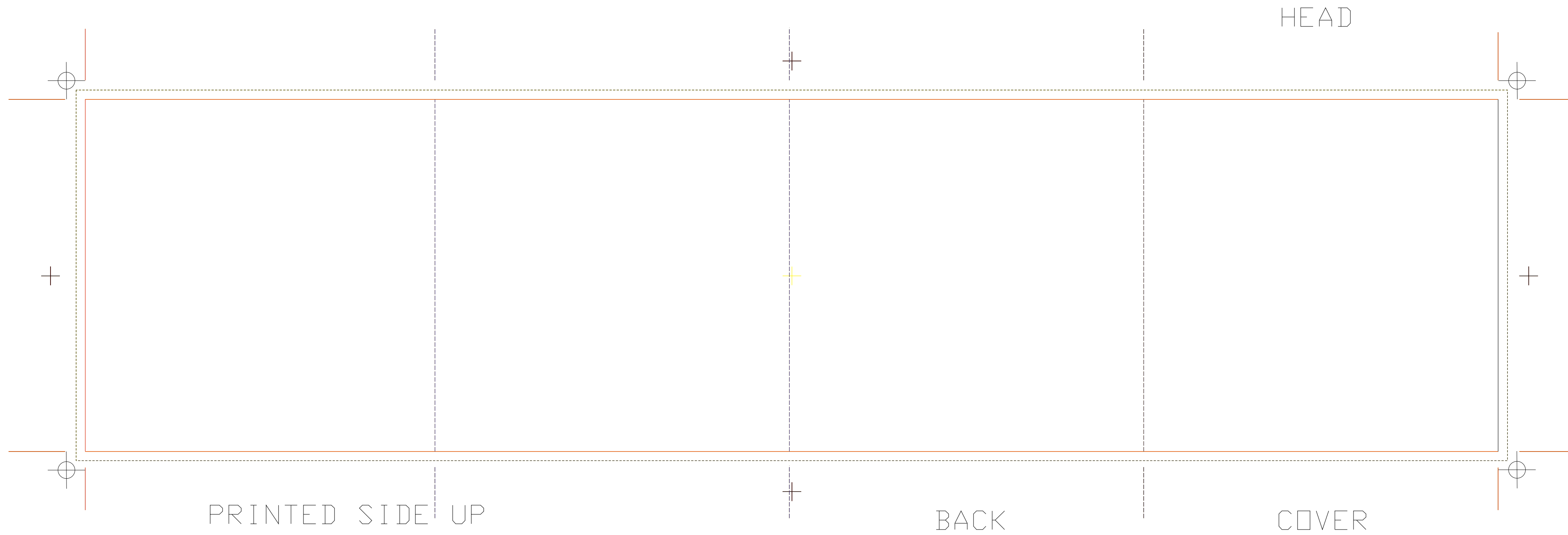

HEAD

BACK

COVER

PRINTED SIDE UP

REF. 8 PAGES FOLDER " FOLD-TWICE "  
DESIGN # 21005

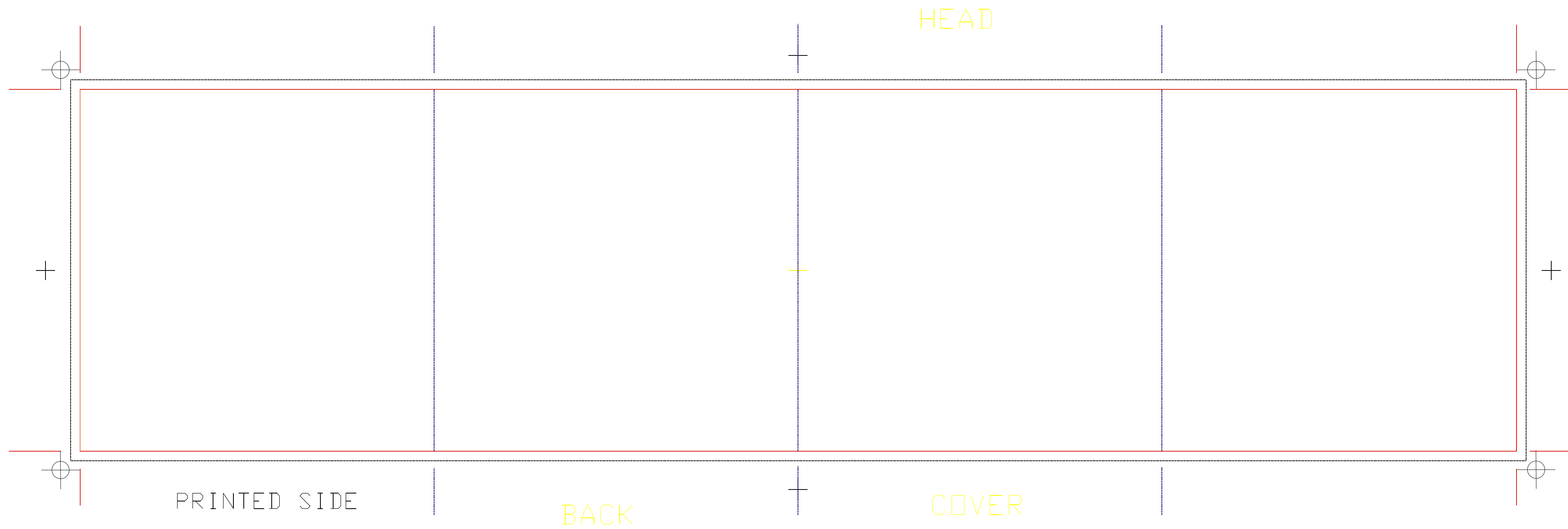

REF. 8 PAGE FOLDER " GATEFOLD "  
DESIGN # 21006

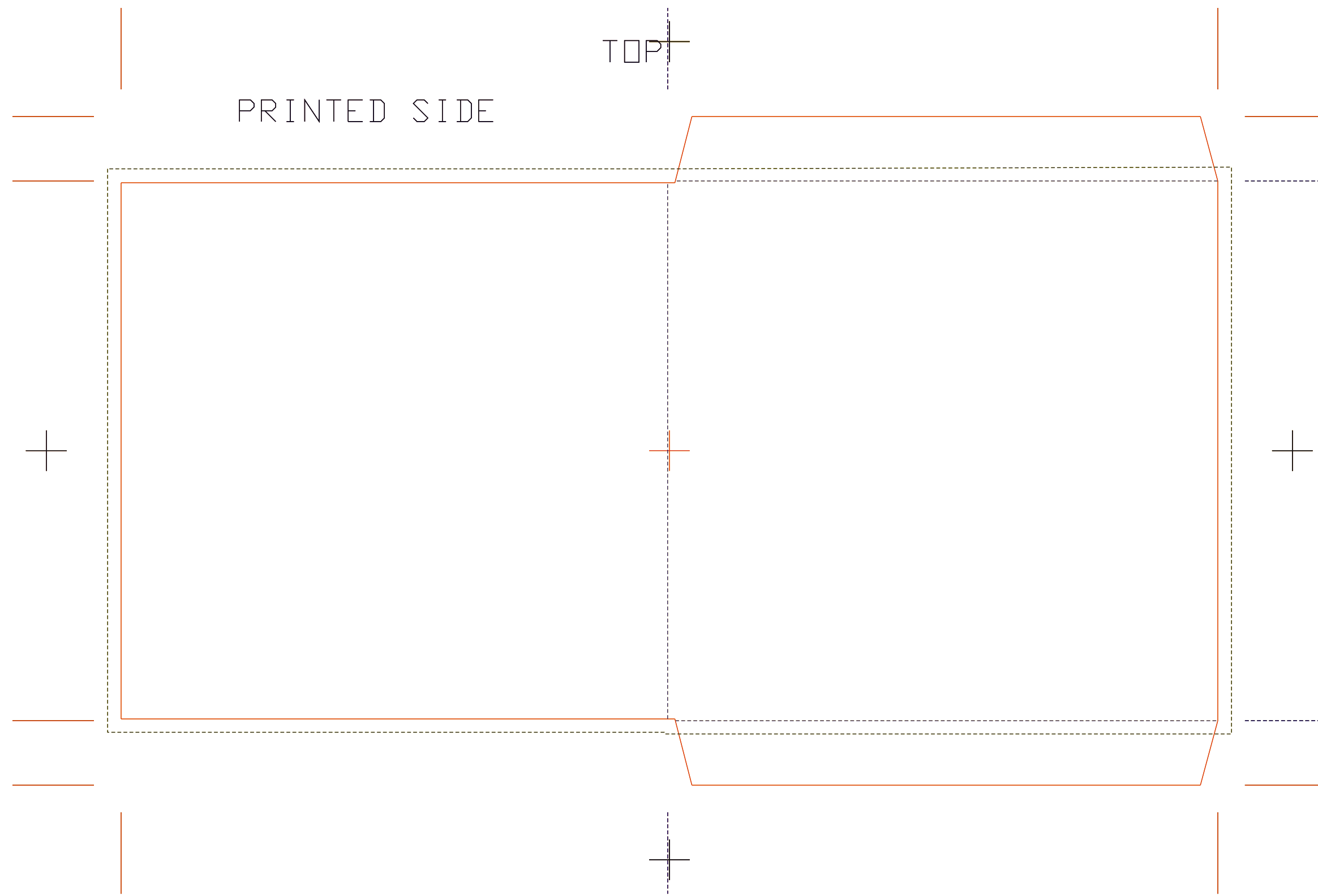

REF: 5" MINI JACKET INSIDE SEAM. Amtech <http://www.amtechdisc.com> 1-800-777-1927  
4.9688" X 5.0625" 55 Duke Montreal, QC Canada H3C 2L8  
R/R: X = 10.0938, Y = 6.1566  
PGM #: 1000  
97/03/24  
FTP design to <ftp://ftp.amtechdisc.com>  
user: anonymous password: not required

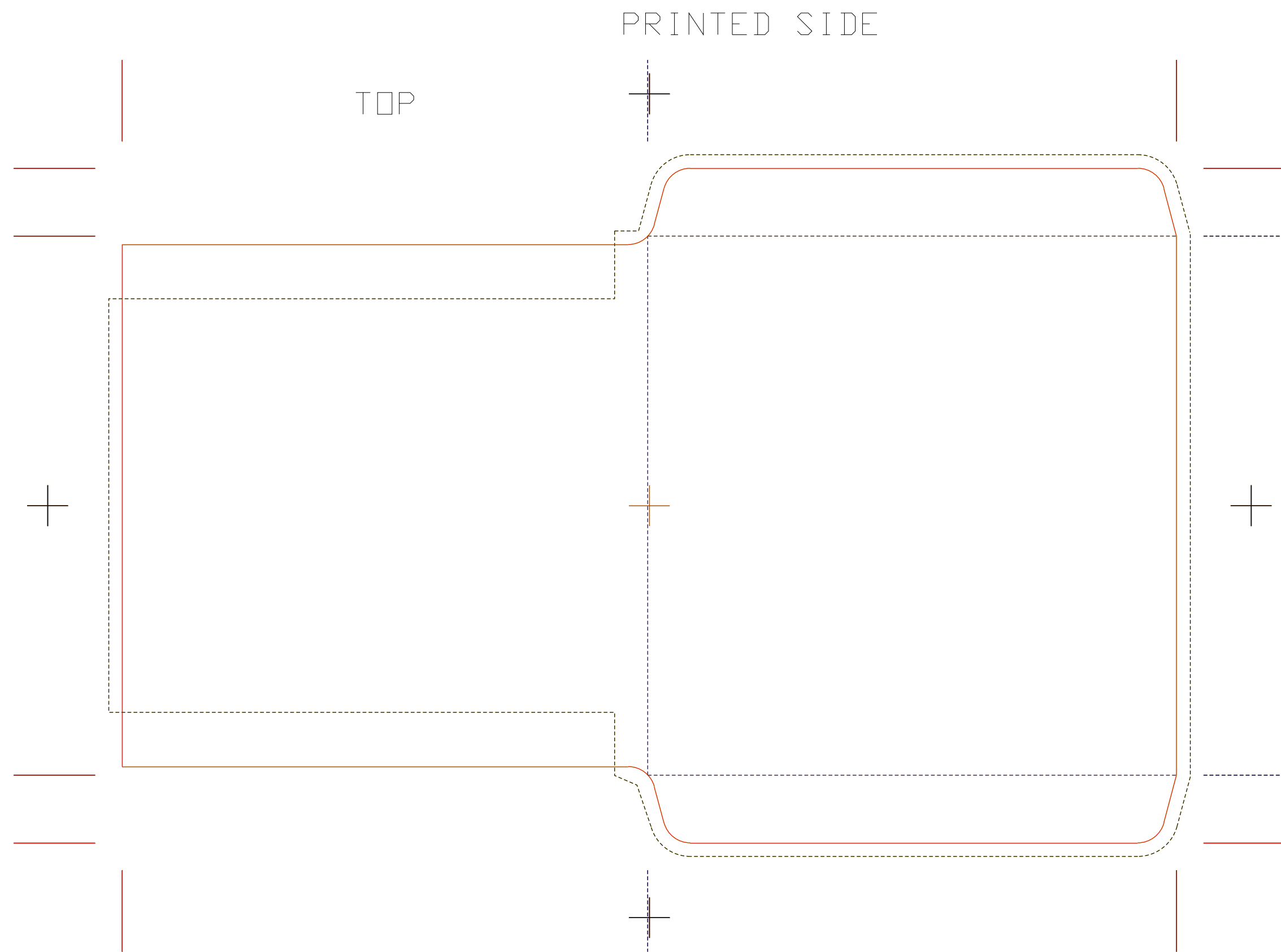

REF: 5" MINI JACKET OUTSIDE SEAM  
4.968" X 4.875  
R/R: X = 9.7188, Y = 6.2188  
PGM #: 1001  
97/03/24

Amtech <http://www.amtechdisc.com> 1-800-777-1927  
55 Duke Montreal, QC Canada H3C 2L8

FTP design to <ftp://ftp.amtechdisc.com>  
user: anonymous password: not required

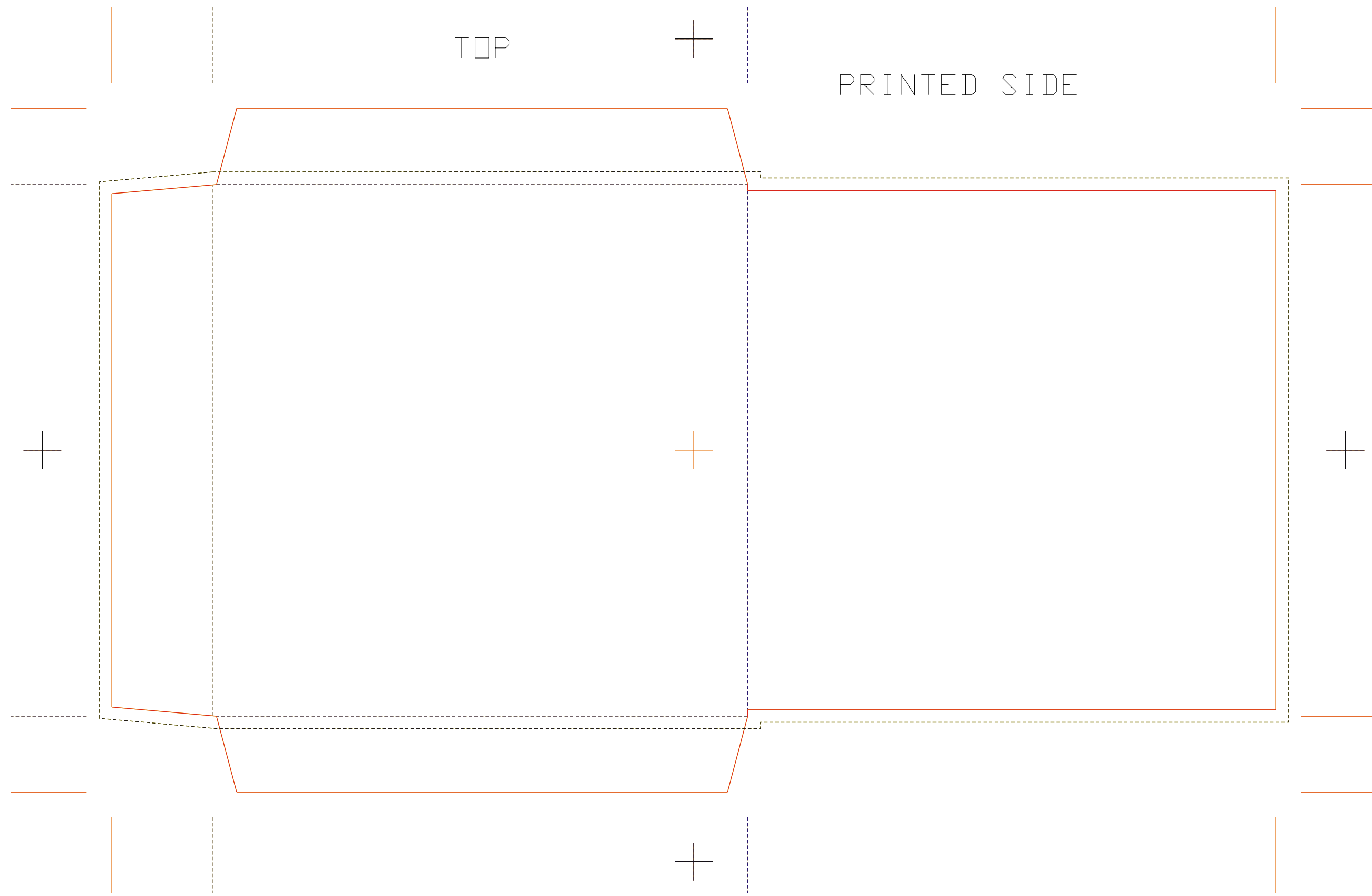

REF: MAILER 5.1/4" WITH 1" FLAP  
5.25" X 5.2812"  
R/R: X = 11.5000, Y = 6.7500  
PGM #: 1002  
97/03/24

Amtech <http://www.amtechdisc.com> 1-800-777-1927  
55 Duke Montreal, QC Canada H3C 2L8

FTP design to <ftp://ftp.amtechdisc.com>  
user: anonymous password: not required

PRINTED SIDE

TOP +

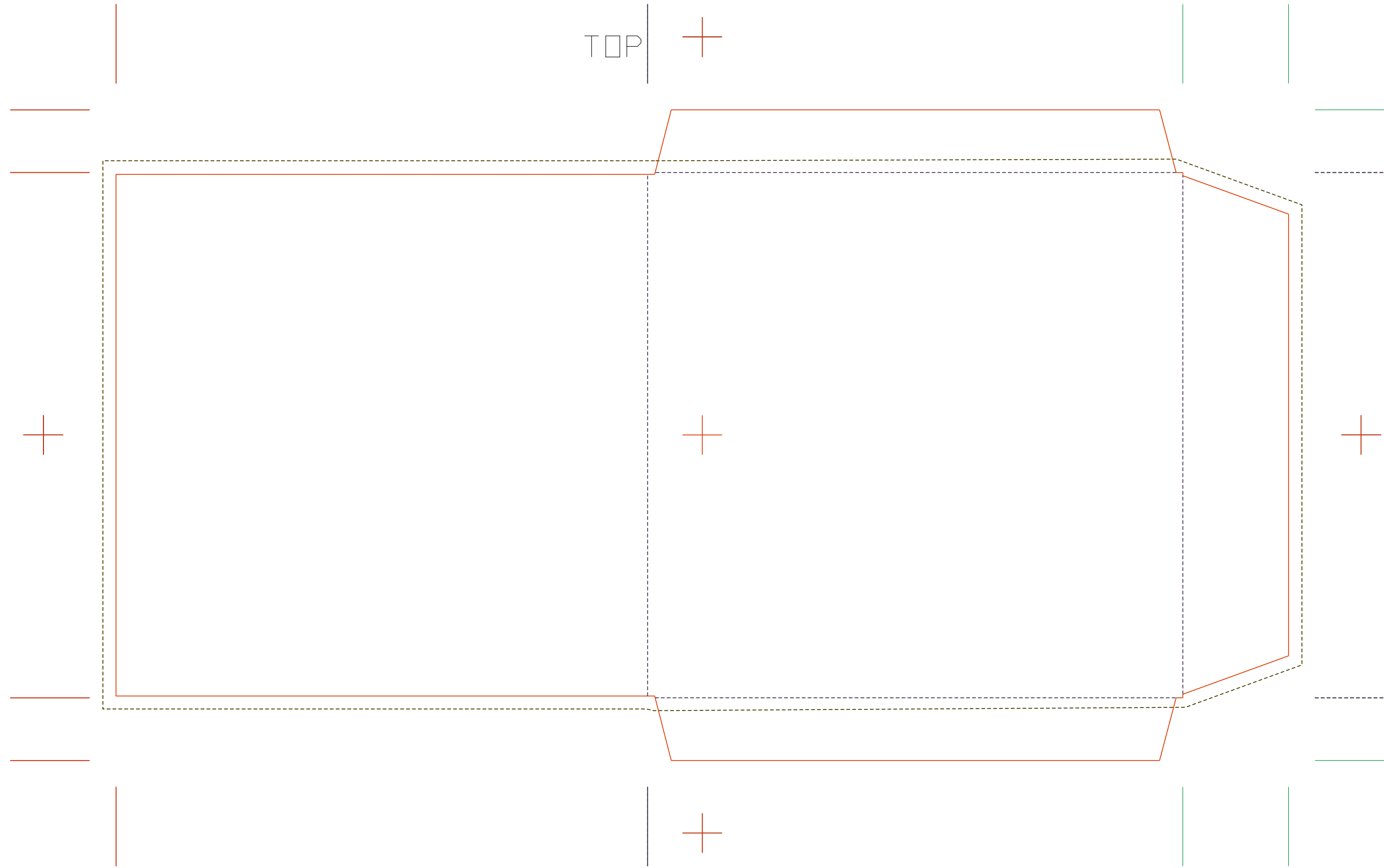

REF: MAILER 5" WITH 1" FLAP & TAPE  
4.9688" X 5.0625"  
R/R: X = 11.0938, Y = 6.1566  
PGM #: 1003  
97/03/24

Amtech <http://www.amtechdisc.com> 1-800-777-1927  
55 Duke Montreal, QC Canada H3C 2L8

FTP design to <ftp://ftp.amtechdisc.com>  
user: anonymous password: not required



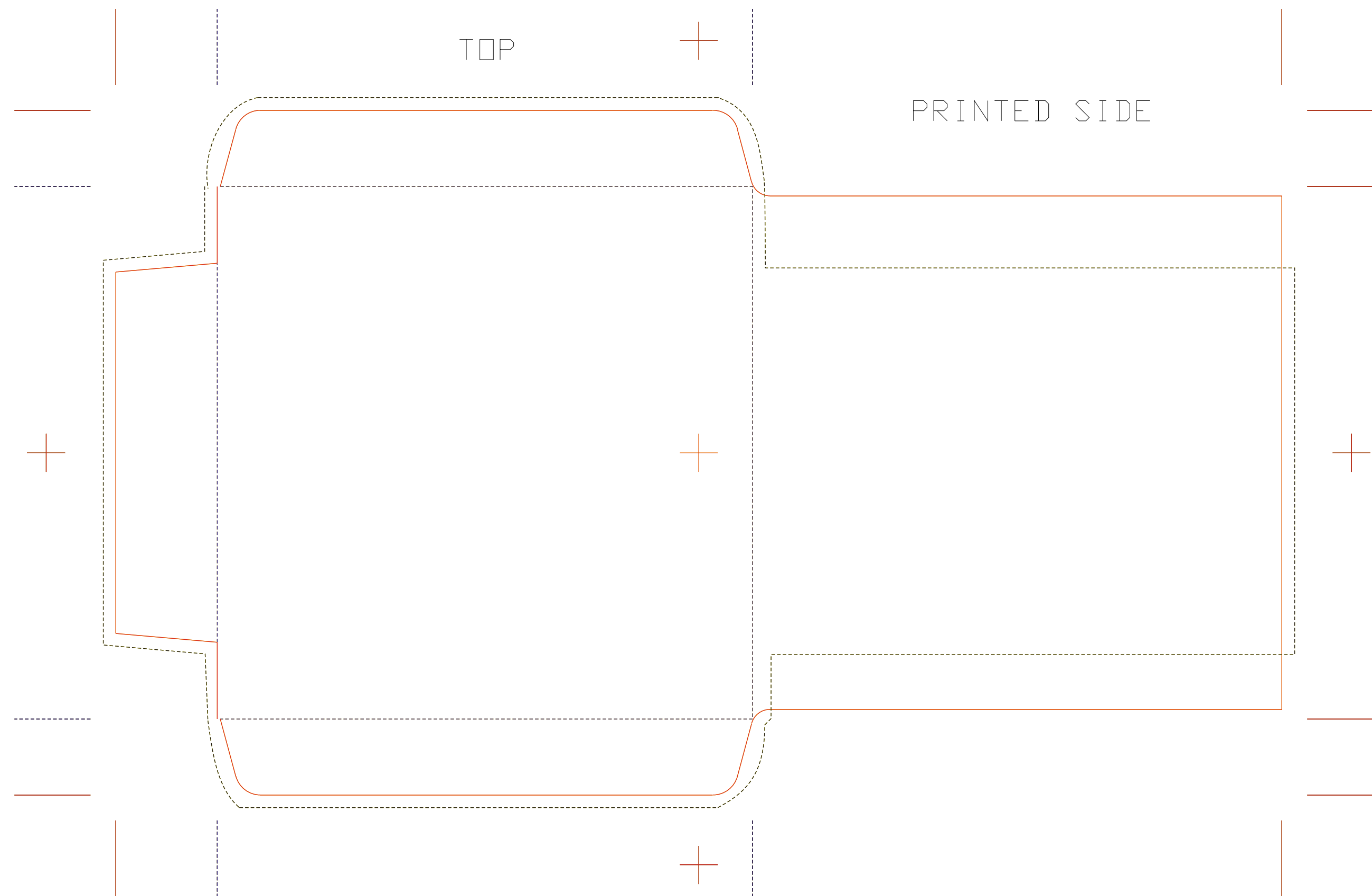

REF: MAILER 5.1/4" WITH 1" FLAP & T  
5.25" X 5.2812"  
R/R: X = 11.5000, Y = 6.7500  
PGM #: 1004  
97/03/24  
NB: OUTSIDE SEAMS

Amtech <http://www.amtechdisc.com> 1-800-777-1927  
55 Duke Montreal, QC Canada H3C 2L8

FTP design to <ftp://ftp.amtechdisc.com>  
user: anonymous password: not required

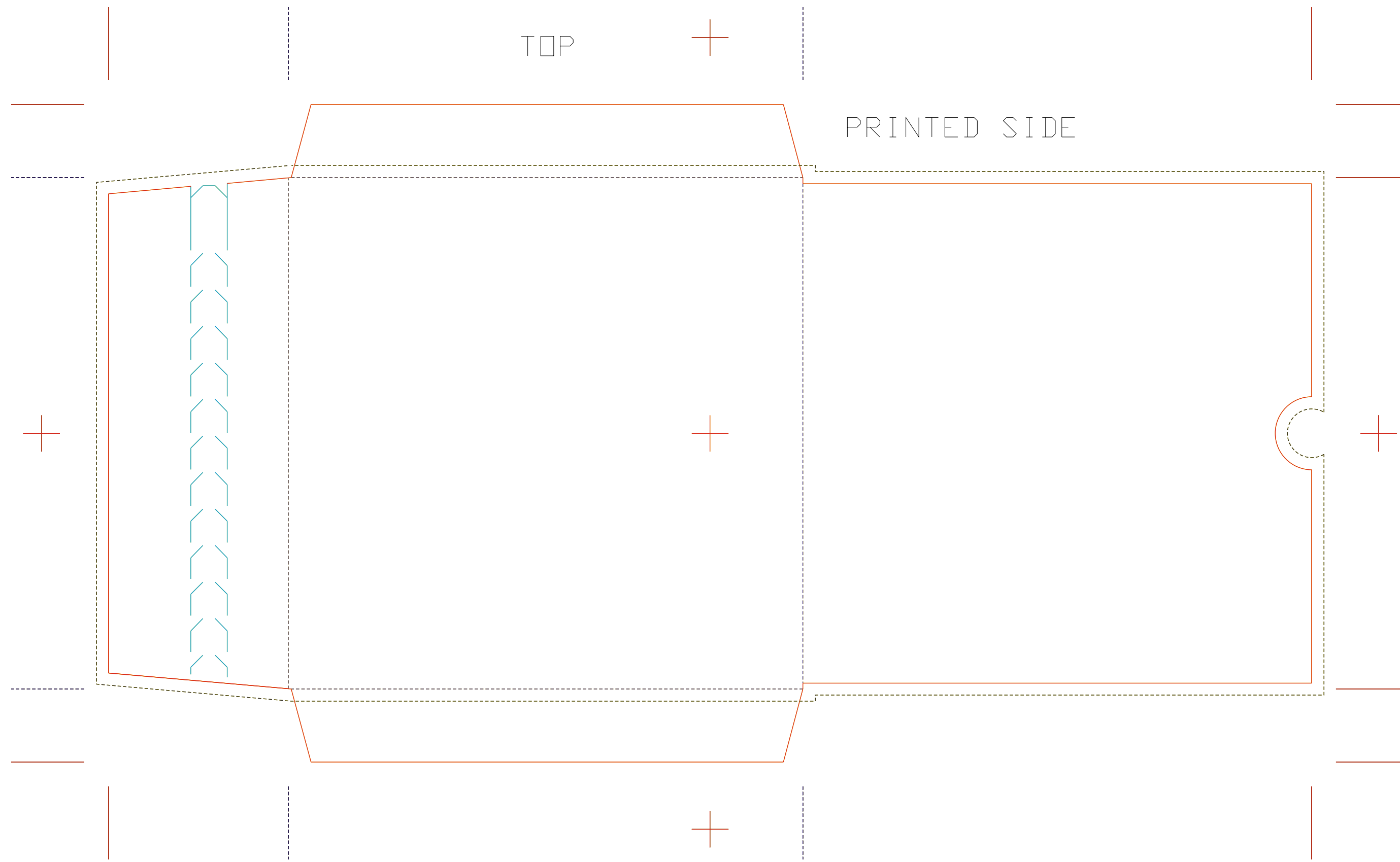

REF: MAILER 5.1/4" WITH 1.75" FLAP  
5.25" X 5.2812"  
R/R: X = 12.3438, Y = 6.7500  
PGM #: 1005  
97/03/24

Amtech <http://www.amtechdisc.com> 1-800-777-1927  
55 Duke Montreal, QC Canada H3C 2L8

FTP design to <ftp://ftp.amtechdisc.com>  
user: anonymous password: not required

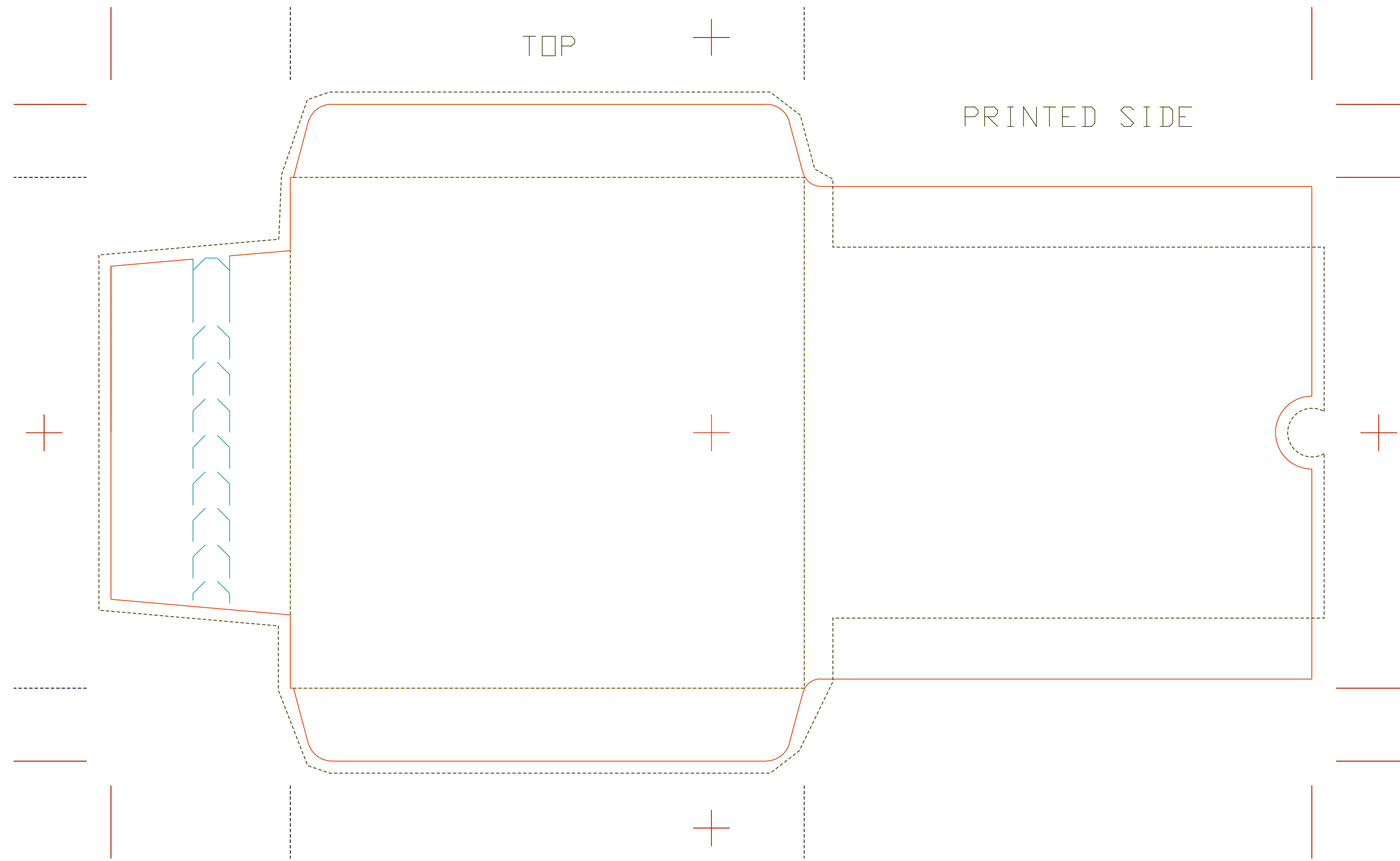

REF: MAILER WITH 1.75" FLAP & ZIP  
 5.25" X 5.2812"  
 R/R: X = 12.3438, Y = 6.7500  
 PGM #: 1006  
 97/03/24  
 NB : OUTSIDE GLUE FLAPS

Amtech <http://www.amtechdisc.com> 1-800-777-1927  
 55 Duke Montreal, QC Canada H3C 2L8

FTP design to <ftp://ftp.amtechdisc.com>  
 user: anonymous password: not required

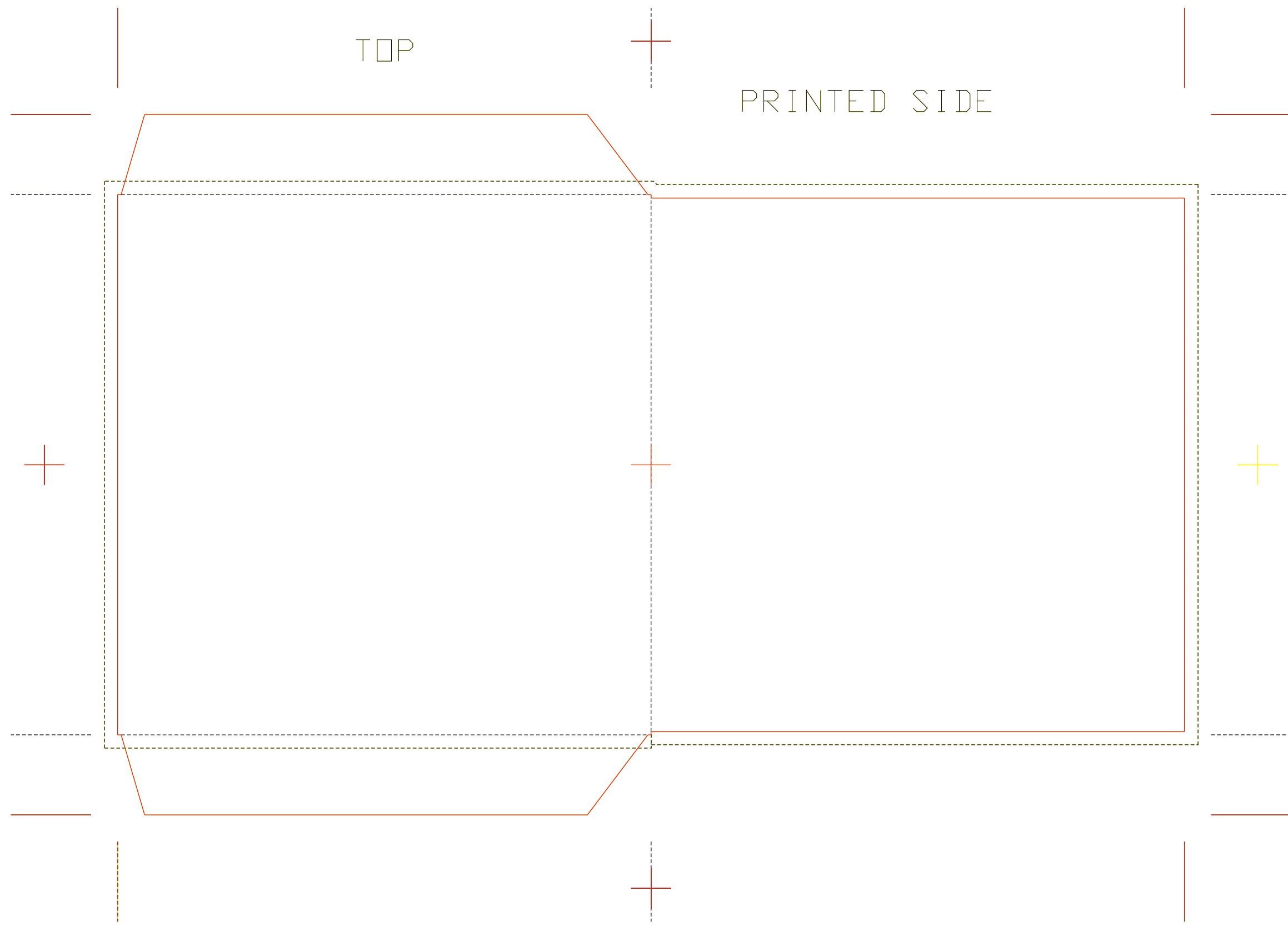

REF: 5" MINI JACKET ( INSIDE SEAMS )  
5.0625" X 5"  
R/R: X = 10.0000, Y = 6.5625  
PGM #: 1007  
97/03/24

Amtech <http://www.amtechdisc.com> 1-800-777-1927  
55 Duke Montreal, QC Canada H3C 2L8

FTP design to <ftp://ftp.amtechdisc.com>  
user: anonymous password: not required

Amtech <http://www.amtechdisc.com> 1-800-777-1927  
55 Duke Montreal, QC Canada H3C 2L8

FTP design to <ftp://ftp.amtechdisc.com>  
user: anonymous password: not required

REF: 4 PANEL 1 CD JACKET  
5.5" X .125" X 5"  
R/R: X = 16.5782, Y = 12.4375  
PGM #: 2000  
97/03/24

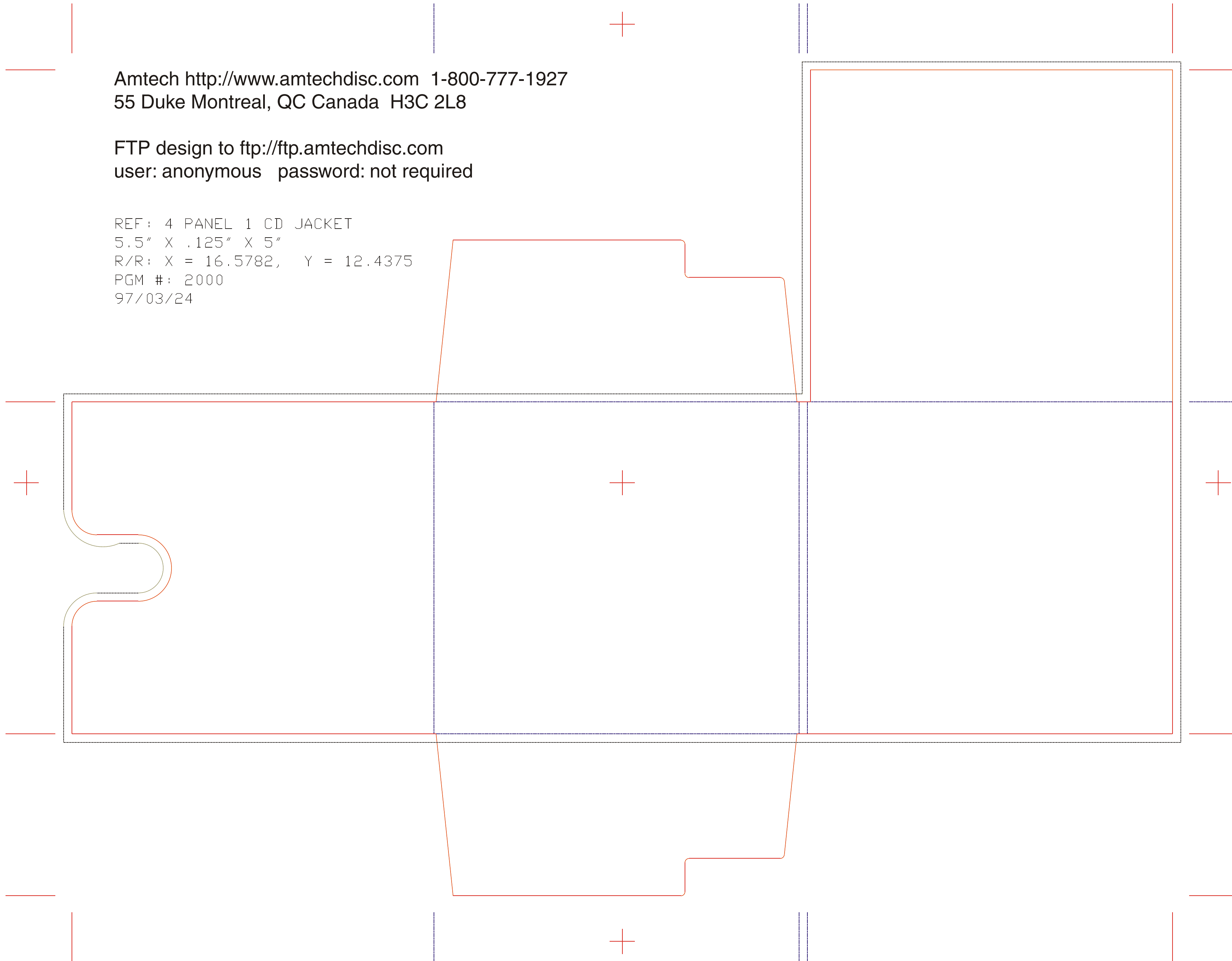

PRINTED SIDE

+ TOP

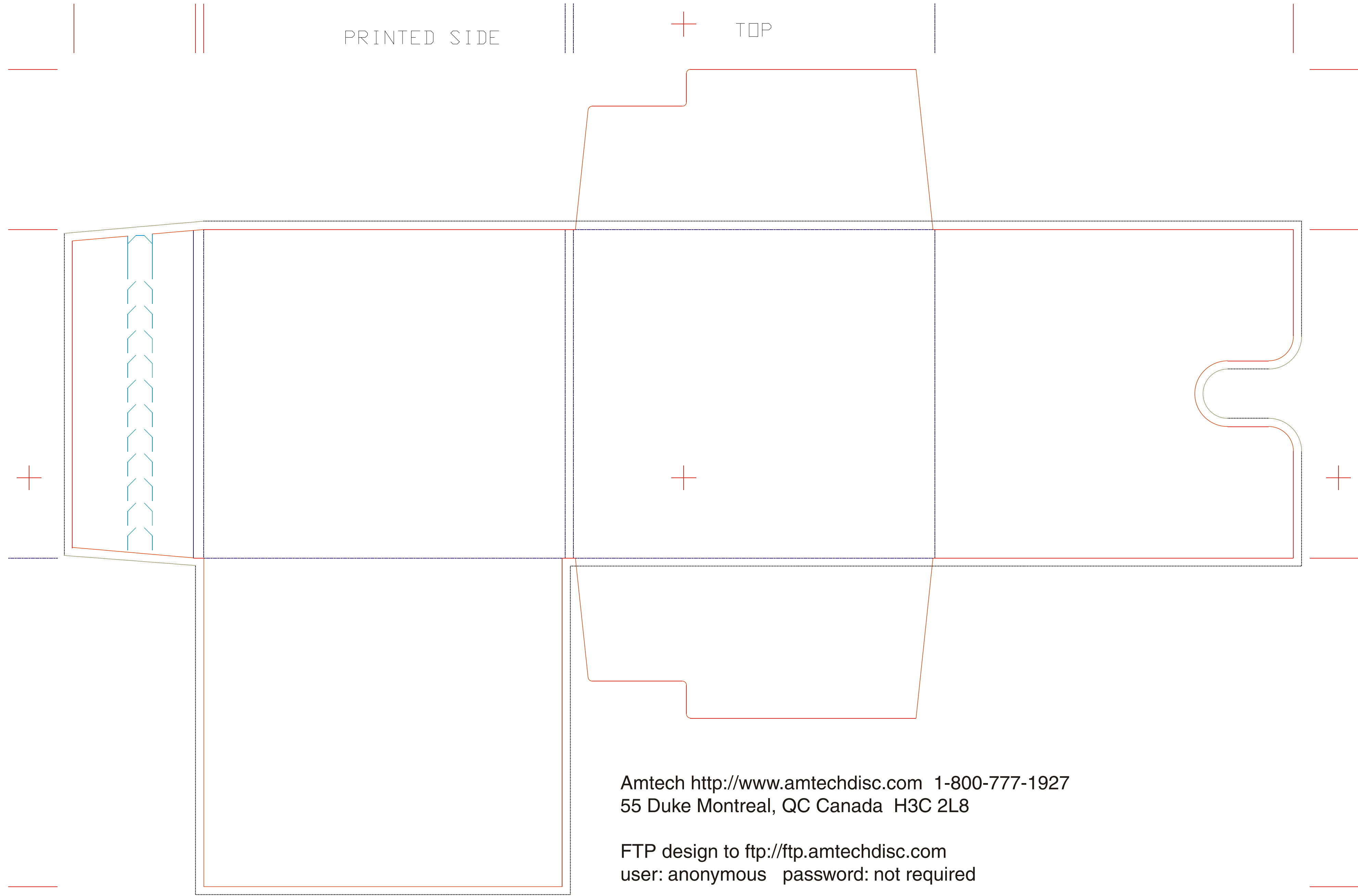

Amtech <http://www.amtechdisc.com> 1-800-777-1927  
55 Duke Montreal, QC Canada H3C 2L8

FTP design to <ftp://ftp.amtechdisc.com>  
user: anonymous password: not required

REF: 4 PANEL (ONE CD) JACKET MAILER  
5.1/2" X .125" X 5"  
R/R: X = 18.5502, Y = 12.4375  
PGM #: 201  
96/11/21  
DB: 12.4375" X 18.5469

+

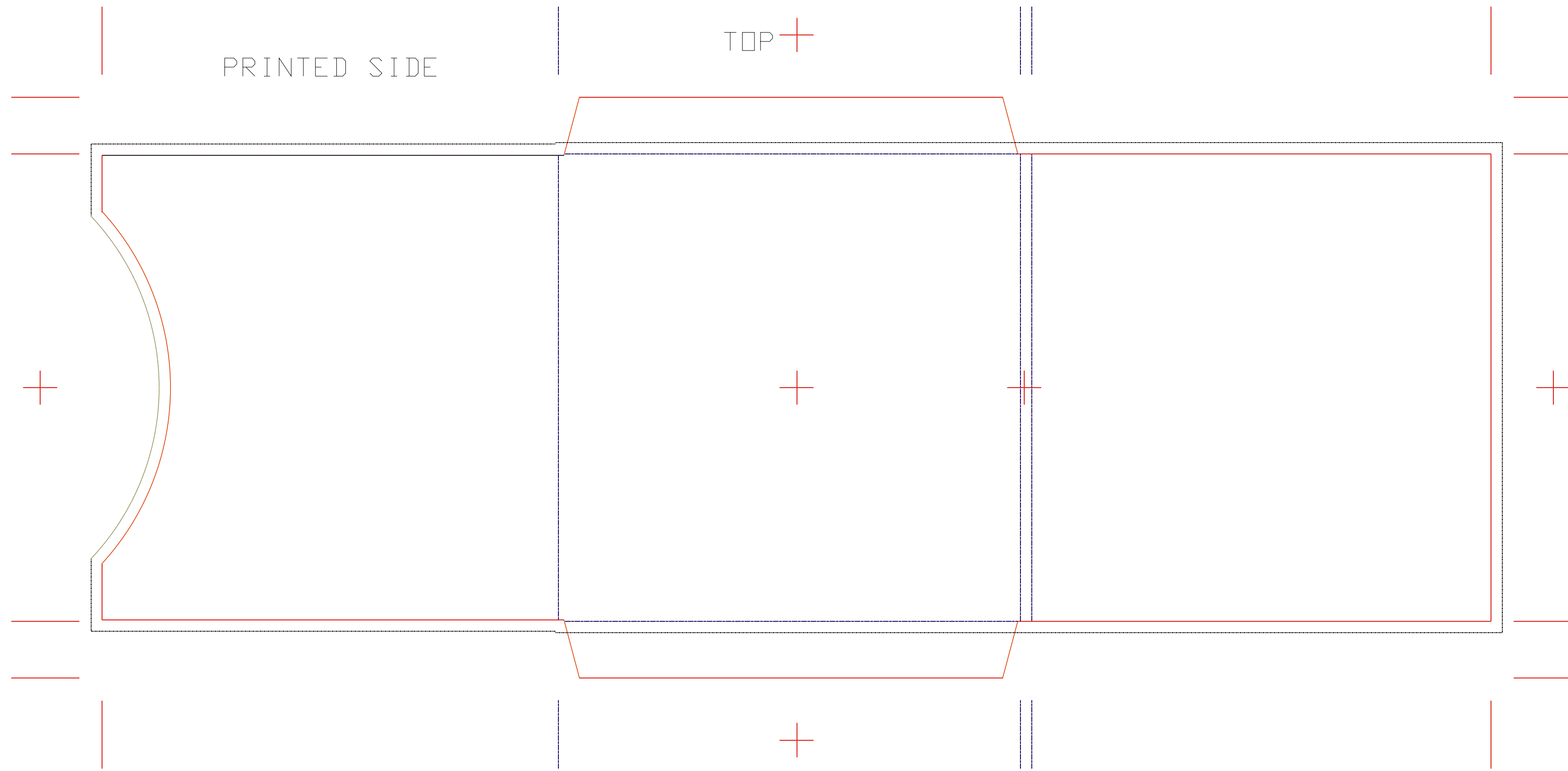

REF: 5" MINI JACKET POUCH STYLE  
5.3/32" X .125" X 5.5/32  
R/R: X = 15.3125, Y = 6.4063  
PGM #: 2002  
97/03/25

Amtech <http://www.amtechdisc.com> 1-800-777-1927  
55 Duke Montreal, QC Canada H3C 2L8

FTP design to <ftp://ftp.amtechdisc.com> user: anonymous password: not required



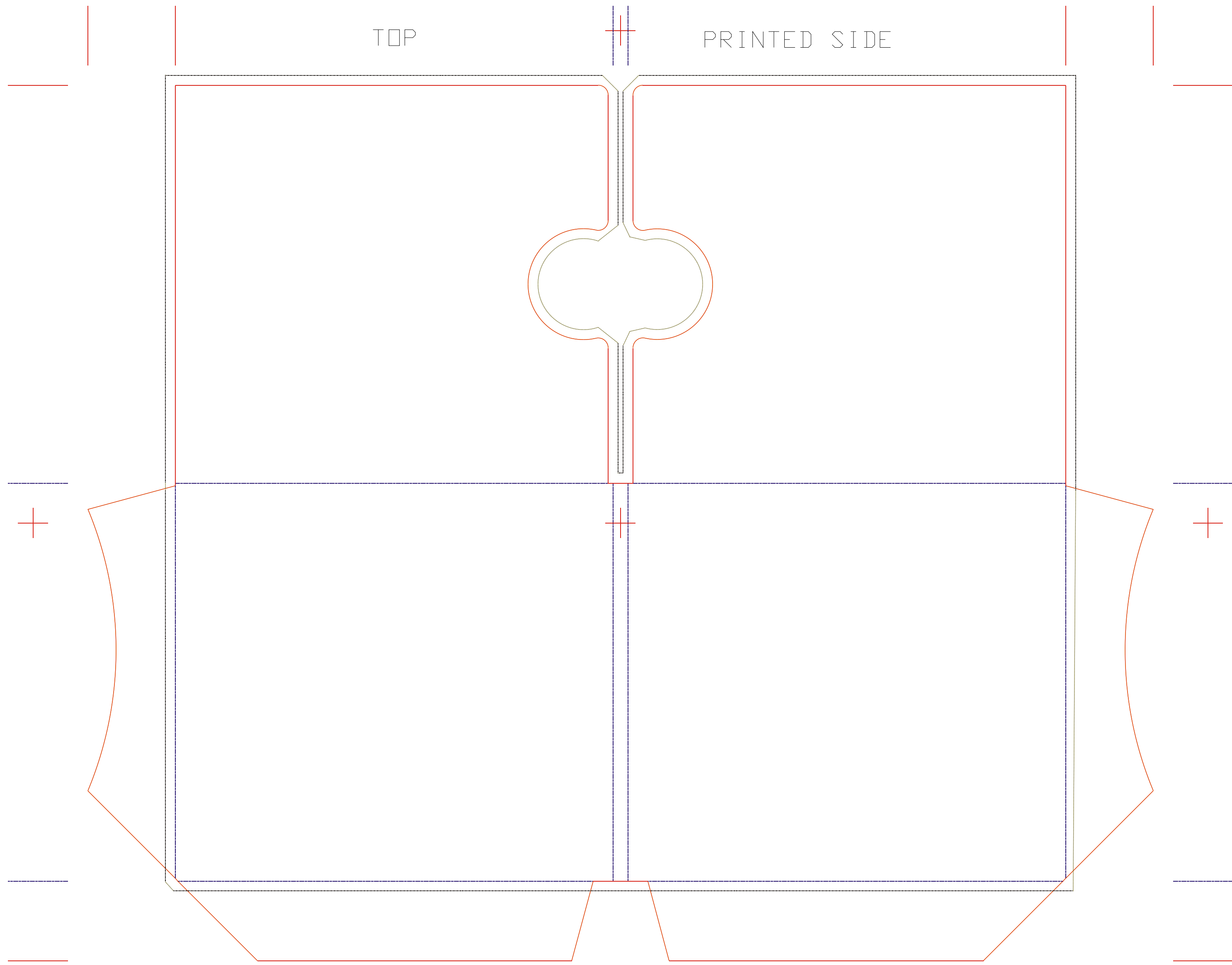

REF: 4 PANEL 2 CD JACKET.  
5.4996" X .1875" X 5"  
R/R: X = 13.3871, Y = 11.0000  
PGM #: 2003  
97/03/25

Amtech <http://www.amtechdisc.com>  
1-800-777-1927  
55 Duke Montreal, QC Canada H3C 2L8  
FTP design to <ftp://ftp.amtechdisc.com>  
user: anonymous password: not required

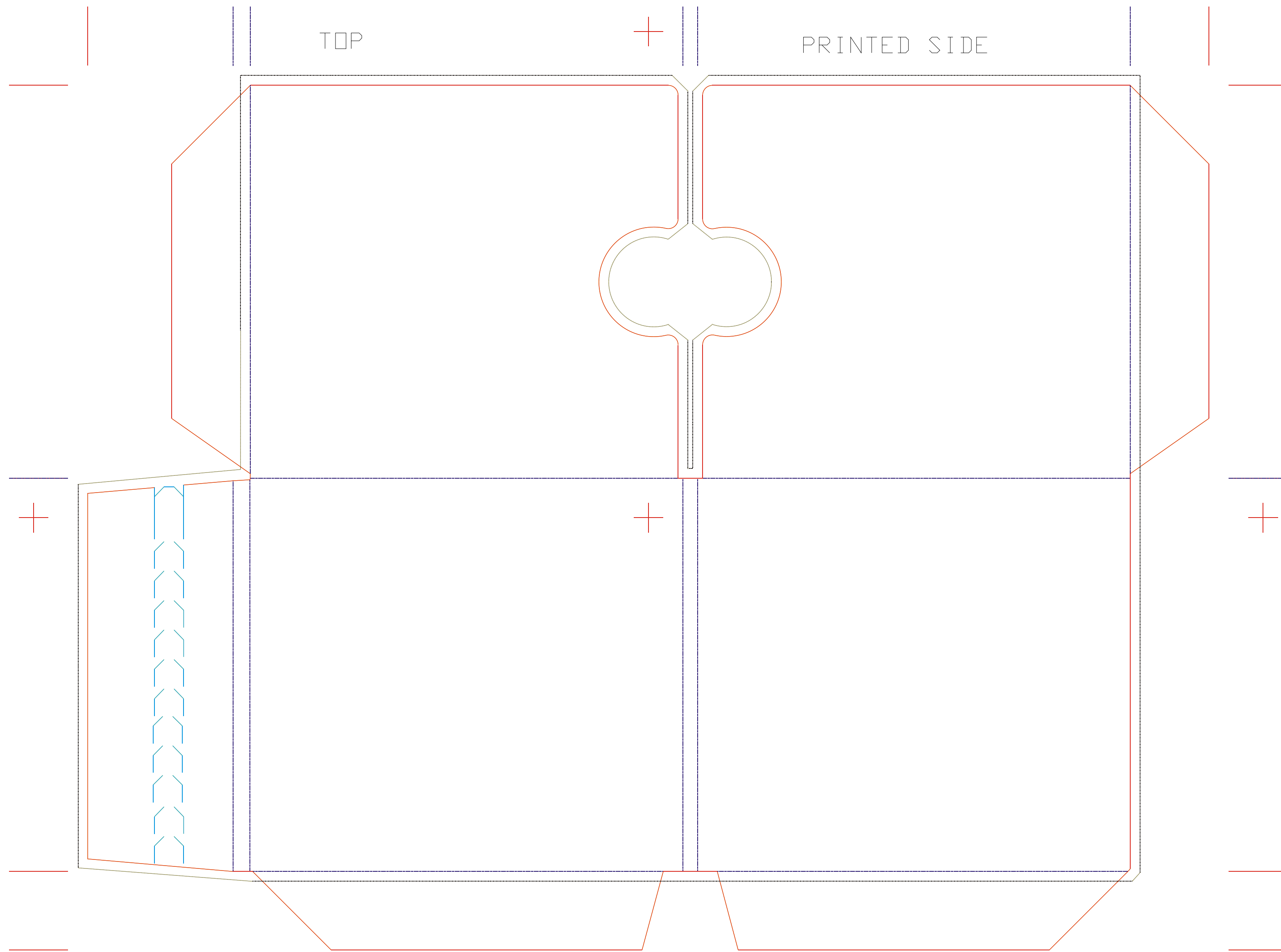

REF: 4 PANEL 2 CD MAILER WITH ZIP  
5.1/2" X 3/16" X 5"  
R/R: X = 14.2522, Y = 11.0000  
PGM #: 2004  
97/03/25

Amtech <http://www.amtechdisc.com>  
1-800-777-1927  
55 Duke Montreal, QC Canada H3C 2L8  
FTP design to <ftp://ftp.amtechdisc.com>  
user: anonymous password: not required

TOP

PRINTED SIDE

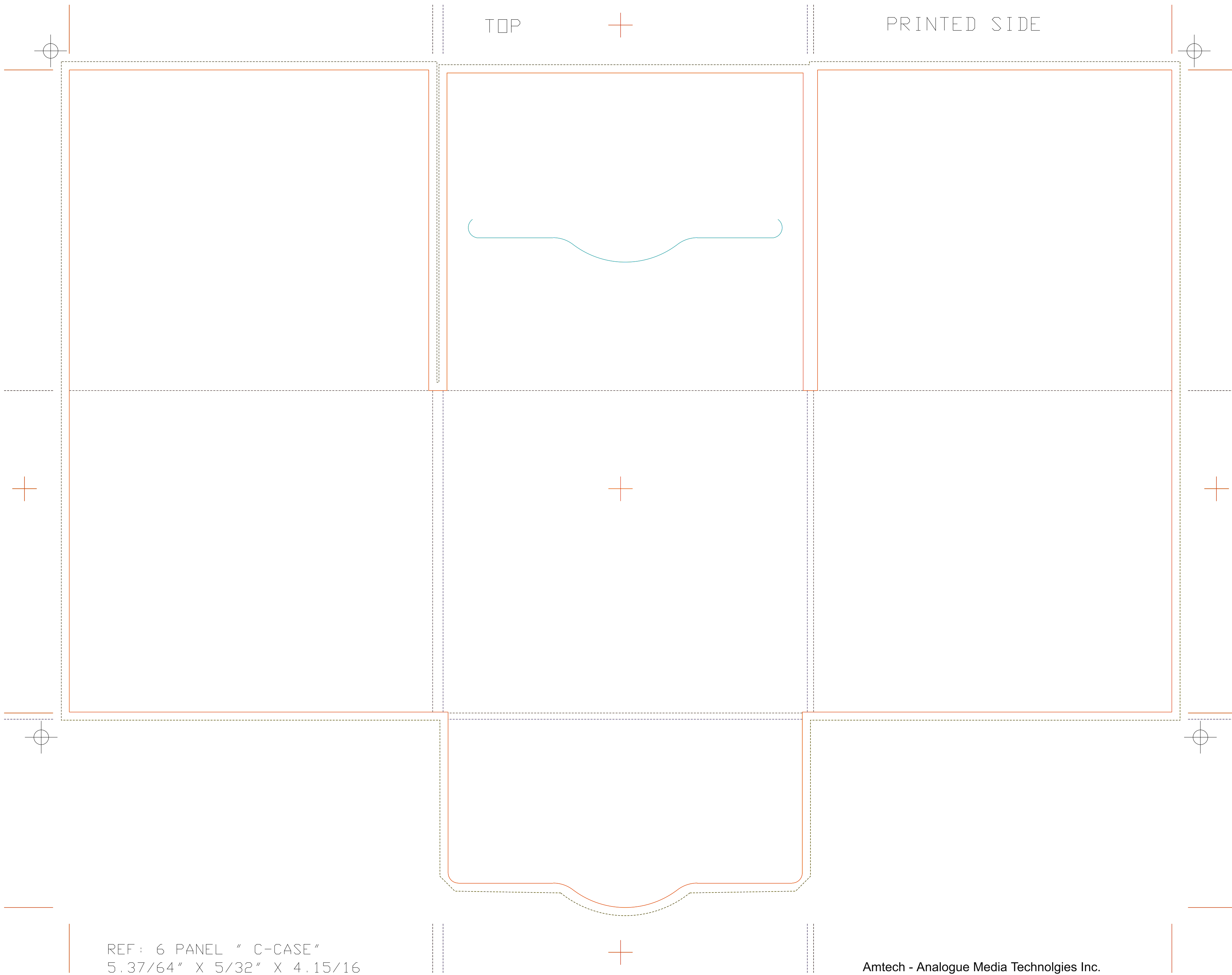

REF: 6 PANEL " C-CASE "  
5.37/64" X 5/32" X 4.15/16  
R/R: X = 16.9219, Y = 12.8593  
PGM #: 3000  
97/03/25

Amtech - Analogue Media Technologies Inc.  
55 Duke, Montreal, Quebec H3C 2L8  
1-800-777-1927 (514) 878-8273  
<http://www.amtechdisc.com>

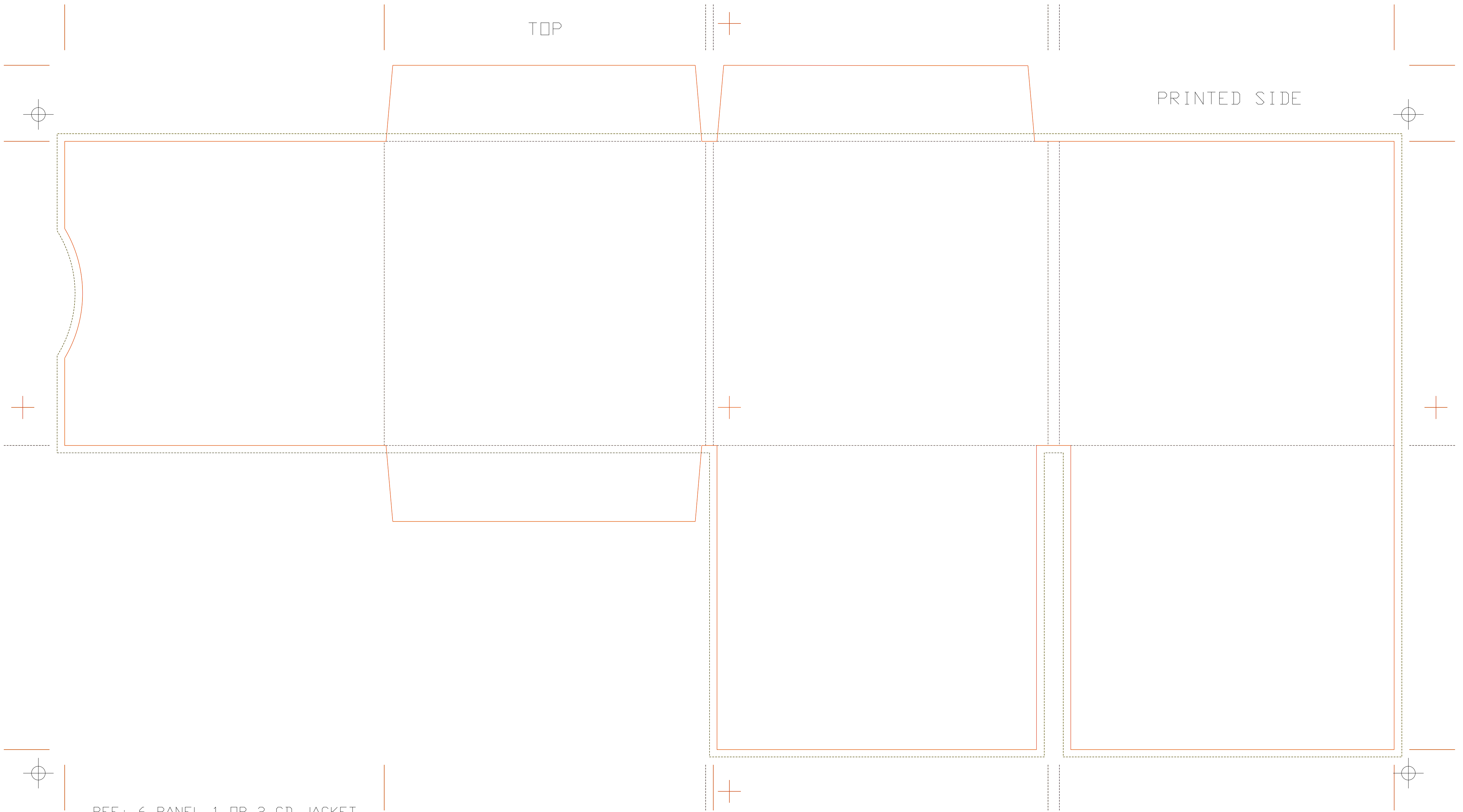

REF: 6 PANEL 1 OR 2 CD JACKET  
5.1/2" X 1/8" X 5"  
R/R: X = 21.844, Y = 11.250  
PGM #: 3001  
97/03/25

Amtech - Analogue Media Technologies Inc.  
55 Duke, Montreal, Quebec H3C 2L8  
1-800-777-1927 (514) 878-8273  
<http://www.amtechdisc.com>

TOP

PRINTED SIDE

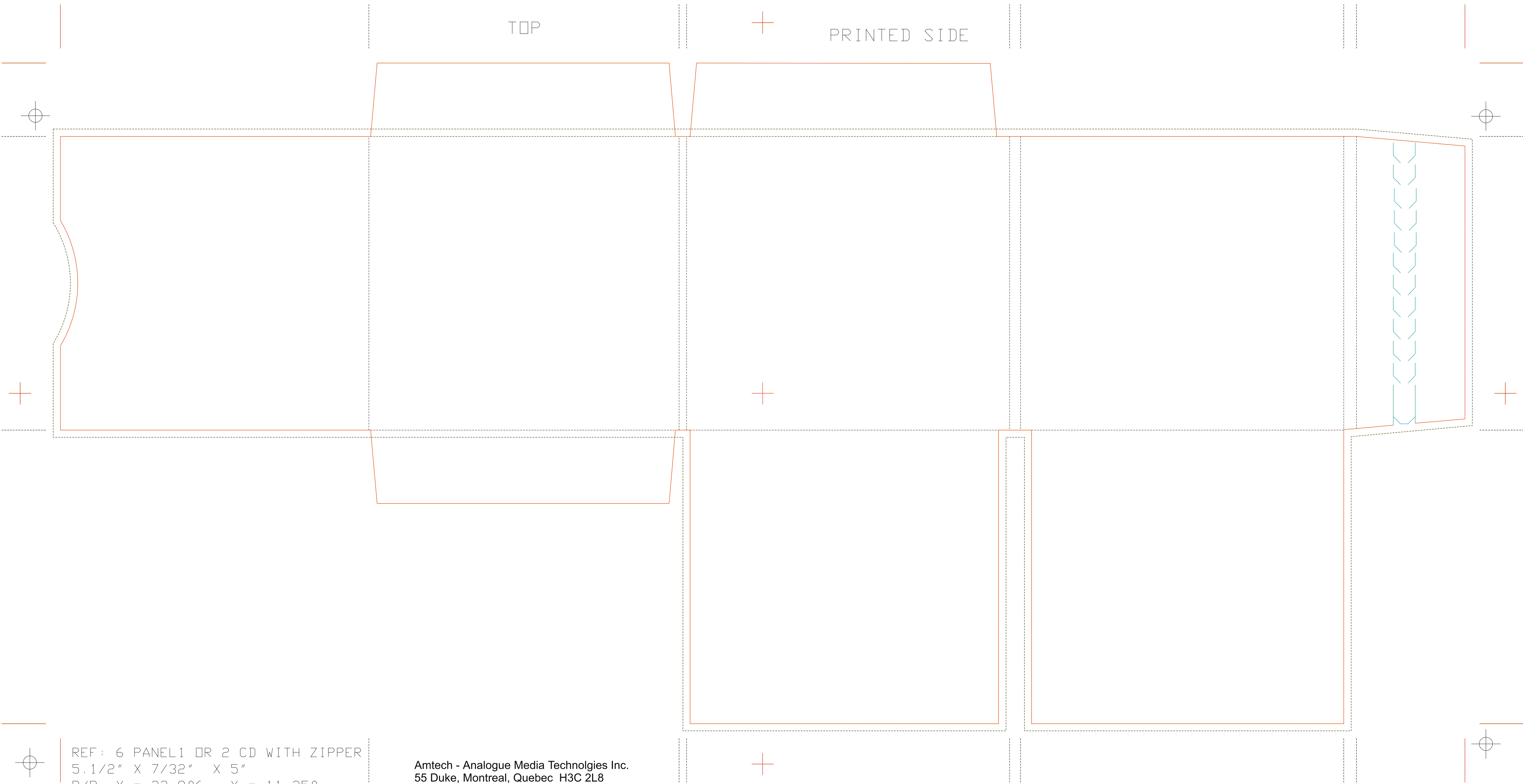

REF: 6 PANEL1 OR 2 CD WITH ZIPPER  
5.1/2" X 7/32" X 5"  
R/R: X = 23.906, Y = 11.250  
PGM #: 3002  
97/03/25

Amtech - Analogue Media Technologies Inc.  
55 Duke, Montreal, Quebec H3C 2L8  
1-800-777-1927 (514) 878-8273  
<http://www.amtechdisc.com>

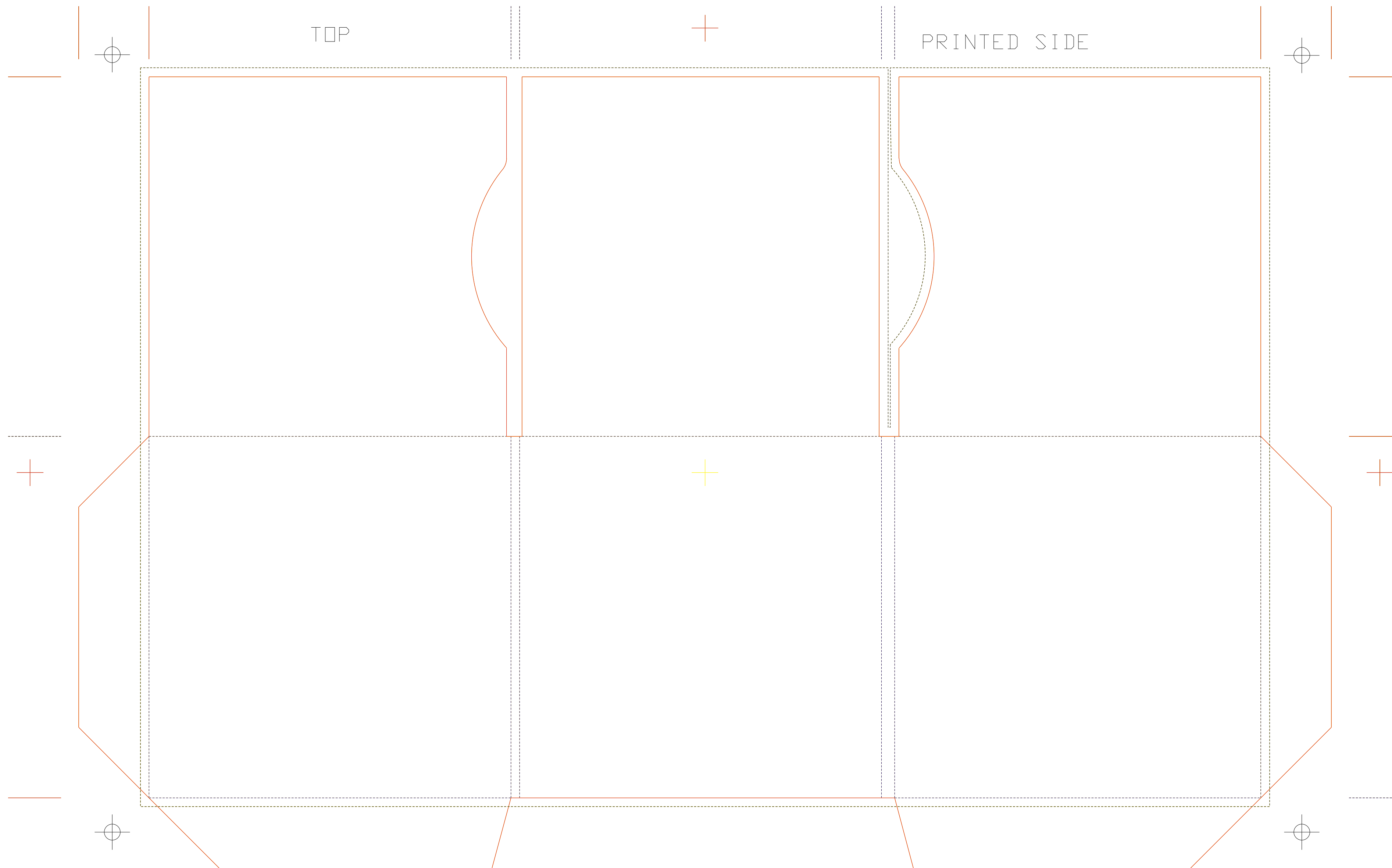

TOP

PRINTED SIDE

REF: 6 PANEL 2CD'S JACKET  
5.3/16 X 3/16 X 5.1/8"  
R/R: X = 17.7500, Y = 11.2187  
PGM #: 3003  
97/01/23

Amtech - Analogue Media Technologies Inc.  
55 Duke, Montreal, Quebec H3C 2L8  
1-800-777-1927 (514) 878-8273  
<http://www.amtechdisc.com>

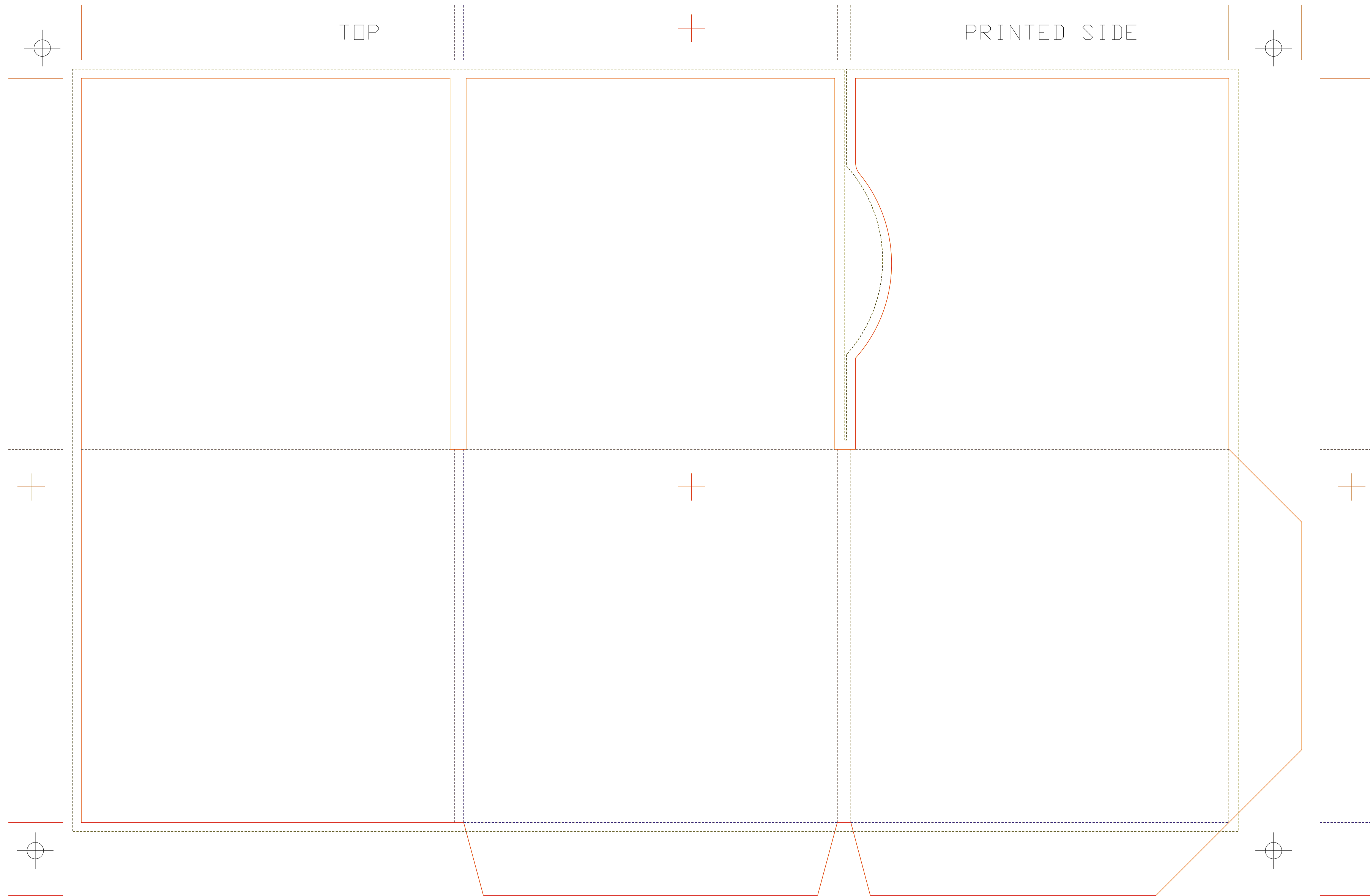

REF: 6 PANEL 1 OR 2 CD'S  
5.3/16" X 3/16" X 5.1/8"  
R/R: X = 16.7500, Y = 11.2187  
PGM #: 3004  
97/03/25

Amtech - Analogue Media Technologies Inc.  
55 Duke, Montreal, Quebec H3C 2L8  
1-800-777-1927 (514) 878-8273  
<http://www.amtechdisc.com>



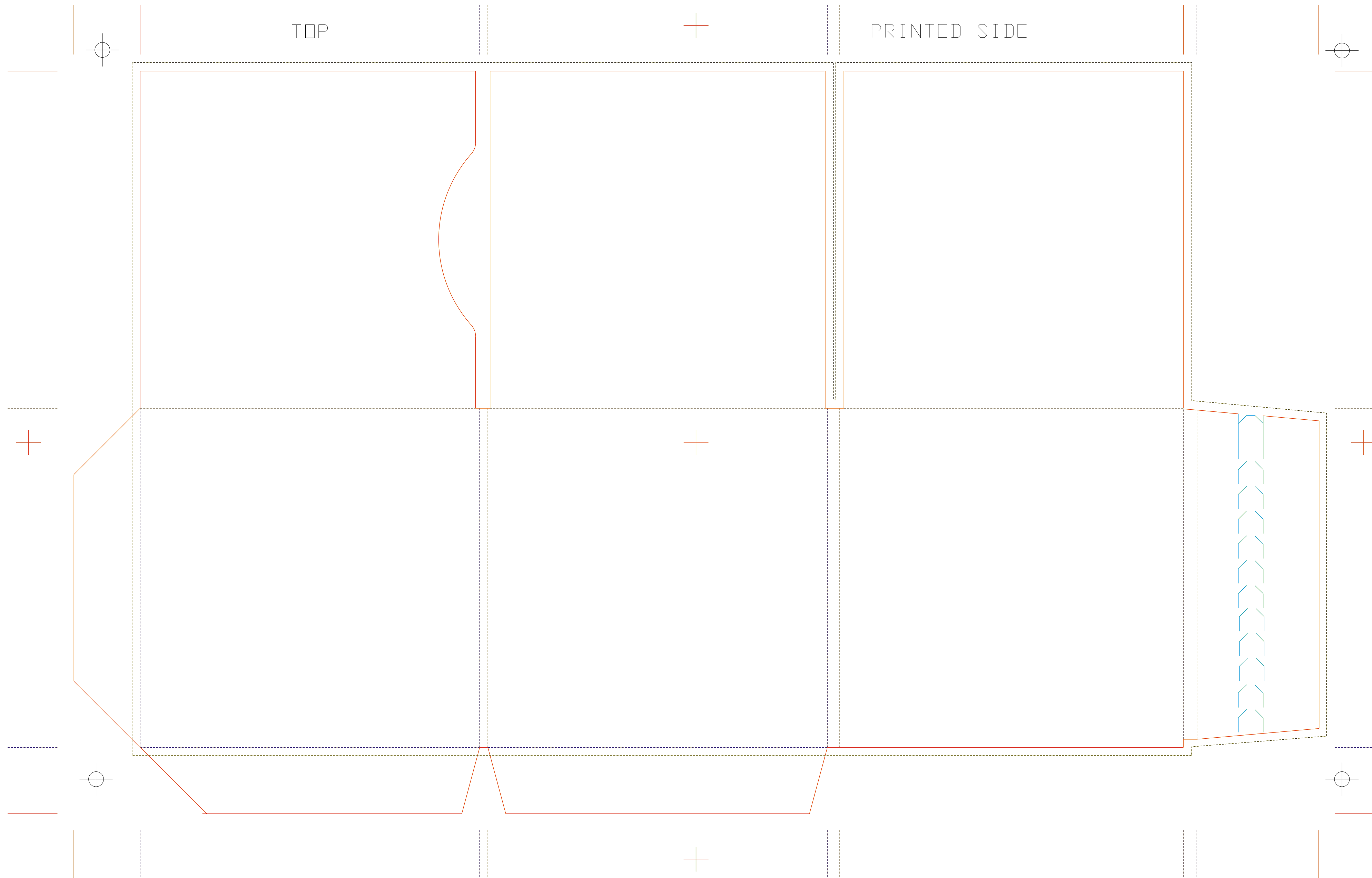

REF: 6 PANEL 1 OR 2 CD JACKET  
 5.3/16" X 3/16" X 5.1/8"  
 R/R: X = 18.7859, Y = 11.2187  
 PGM #: 3005  
 97/03/10

Amtech - Analogue Media Technologies Inc.  
 55 Duke, Montreal, Quebec H3C 2L8  
 1-800-777-1927 (514) 878-8273  
<http://www.amtechdisc.com>

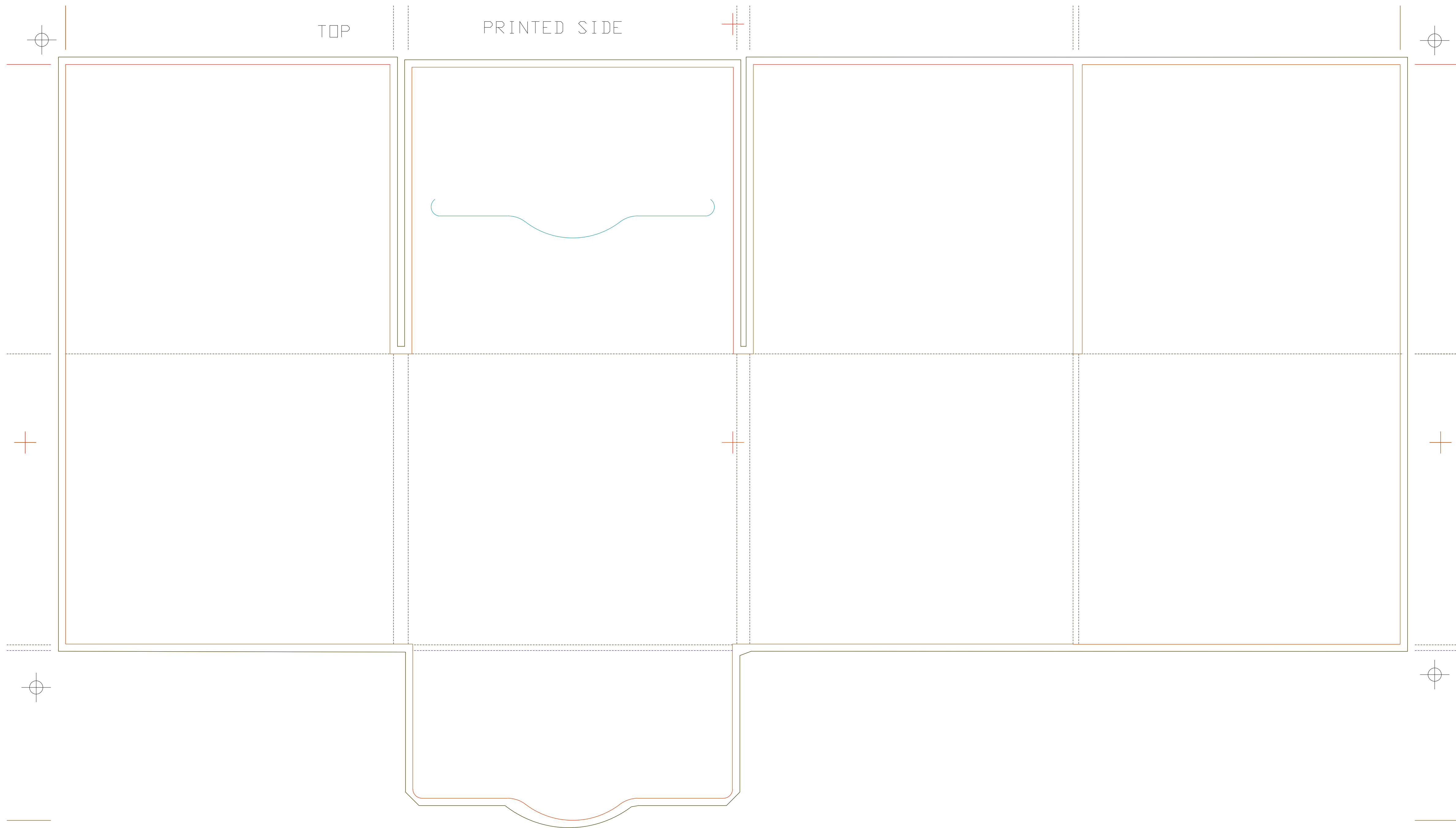



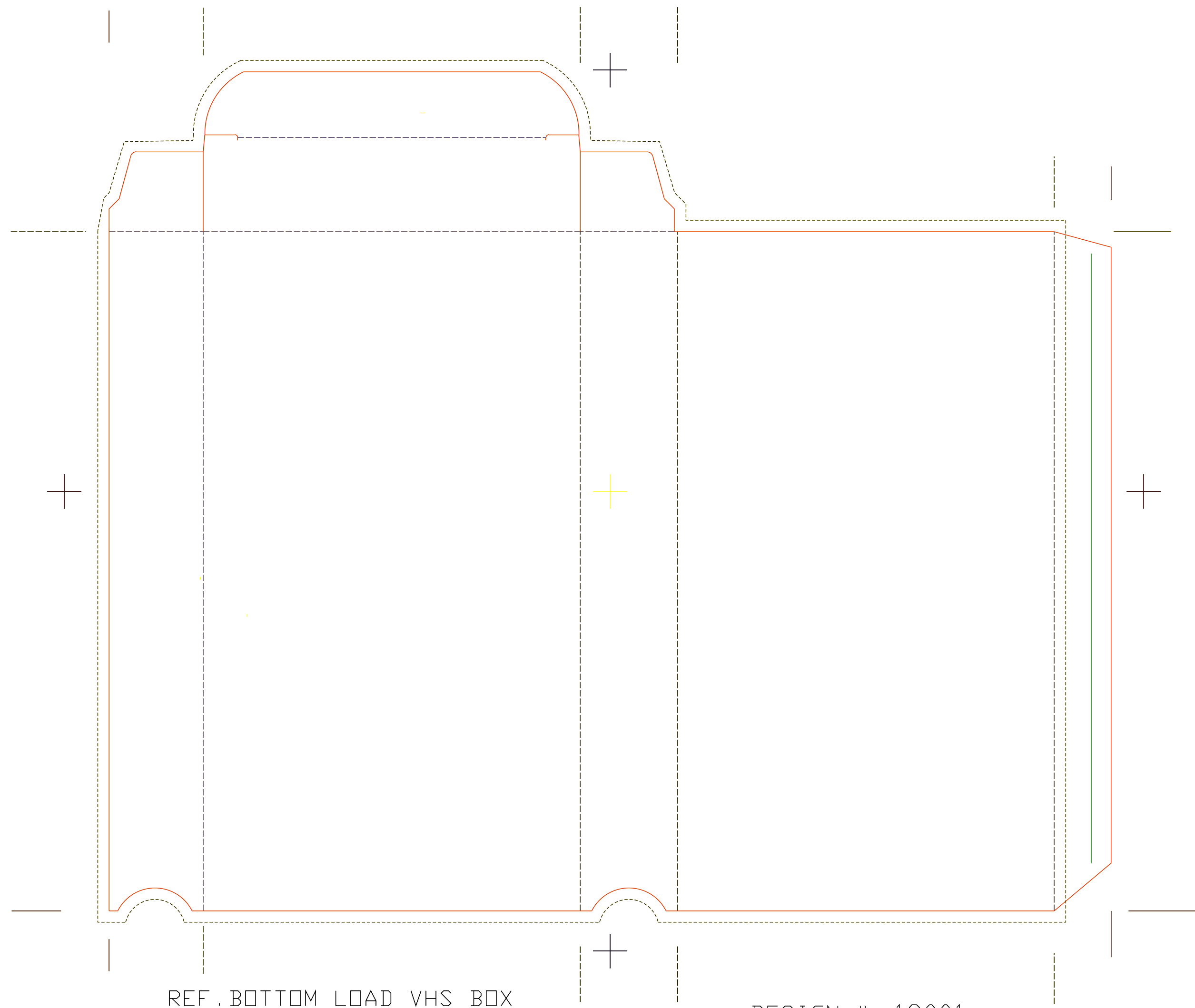

REF: 8 PANEL "C-CASE"  
5.1/2" X 1/4" X 4.15/16"  
R/R: X = 22.6953, Y = 12.8593  
PGM #: 4000  
97/03/25

Amtech - Analogue Media Technologies Inc.  
55 Duke, Montreal, Quebec H3C 2L8  
1-800-777-1927 (514) 878-8273  
<http://www.amtechdisc.com>





Legend:

-  TRIM
-  FOLD
-  PERFORATION
-  MAXIMUM IMAGE (BLEED AREA)

REF. BOTTOM LOAD VHS BOX

DESIGN # 18001

SIZE 4.1/8" X 1.1/16" X 7.7/16"